

Intervention and Extension Resources



Inside you'll find:

- Strategies for effective differentiation
- Mini-Lessons, including those from prior grades
- Extensions

Amplify Desmos Math **FLORIDA**

Grade 7

Intervention and Extension
Resources

About Amplify

Amplify is dedicated to collaborating with educators to create learning experiences that are rigorous and riveting for all students. Amplify creates K–12 core and supplemental curriculum, assessment, and intervention programs for today’s students.

A pioneer in K–12 education since 2000, Amplify is leading the way in next-generation curriculum and assessment. All of our programs provide teachers with powerful tools that help them understand and respond to the needs of every student.

Amplify Desmos Math Florida is based on curricula from Illustrative Mathematics (IM). IM 6–8 Math was originally developed by Open Up Resources and authored by Illustrative Mathematics, and is © 2017–2019 Open Up Resources. Additional adaptations and updates to IM 6–8 Math are © 2019 Illustrative Mathematics. IM 6–8 Math is licensed under the Creative Commons Attribution 4.0 International license (CC BY 4.0). Additional modifications contained in Amplify Desmos Math are © 2023 Amplify Education, Inc. and its licensors. Amplify is not affiliated with the Illustrative Mathematics organization.

The *Universal Design for Learning Guidelines* version 2.2 were developed by the Center for Applied Special Technology (CAST). © 2018 CAST.

The “Effective Mathematics Teaching” practices were developed by the National Council of Teachers (NCTM) in *Principles to Actions: Ensuring Mathematical Success for All*. © 2014 NCTM.

The “Procedural Fluency in Mathematics” practices were developed by the National Council of Teachers of Mathematics (NCTM) in *Procedural Fluency: Reasoning and Decision-Making, Not Rote Application of Procedures Position*. © 2023 NCTM.

Desmos® is a registered trademark of Desmos Studio PBC.

Notice and Wonder® and I Notice/I Wonder™ are trademarks of the National Council of Teachers. Amplify Desmos Math is not sponsored, endorsed by, or affiliated with the National Council of Teachers.

No part of this publication may be reproduced or distributed in any form or by any means without the prior written consent of Amplify Education, Inc., except for the classroom use of the worksheets included for students in some lessons, or as otherwise permitted under the Acceptable Use Policy posted on our website, which is subject to change at any time without notice to you and/or your organization.

Amplify gratefully acknowledges the work of distinguished program advisors from English Learners Success Forum (ELSF), who have been integral in the development of Amplify Desmos Math. ELSF is a 501(c)(3) nonprofit organization whose mission is to expand educational equity for multilingual learners by increasing the supply of high-quality instructional materials that center their cultural and linguistic assets.

© 2028 Amplify Education, Inc.
55 Washington Street, Suite 800
Brooklyn, NY 11201
www.amplify.com

ISBN: 9798895804803
Printed in [e.g., the United States of
America] [# of print run] [print vendor]
[year of printing]

Contents

Mini-Lessons

Log in to the digital curriculum to review all program Mini-Lessons and Extensions.

Unit 1 Scale Drawings	3
1.04 Connecting Scale Factors to Scaled Copies	5
1.10 Determining Unknowns in Scale Drawings	9
Unit 2 Introducing Proportional Relationships	13
2.03 Determining the Constant of Proportionality	15
2.06 Finding More Than One Equation to Represent Proportional Relationships	19
2.10 Comparing Proportional Relationships With Graphs	23
2.11 Representing Proportional Relationships	27
Unit 3 Measuring Circles	31
3.03 Determining the Circumference of a Circle	33
3.06 Determining the Area of a Circle	37
Unit 4 Proportional Relationships and Percentages	41
4.03 Calculating Percentages	43
4.06 Finding Sales Tax and Tip	47
4.10 Applying Fractions in Proportional Relationships	51
Unit 5 Positive and Negative Rational Numbers	55
5.04 Dividing Integers	57
5.07 Multiplying Powers	61
Unit 6 Expressions, Equations, and Inequalities	65
6.02 Writing Equations From Descriptions and Tape Diagrams	67
6.06 Solving Equations with Positive and Negative Numbers	71
6.15 Solving Inequalities	75

Contents **Mini-Lessons** (continued)

Unit 7	Polygons and Cylinders	79
7.01	Calculating the Area of Parallelograms	81
7.04	Calculating Areas of Complex Shapes	85
7.06	Calculating Volumes of Cylinders	89
Unit 8	Probability and Sampling	93
8.03	Predicting Sample Spaces Using Proportional Relationships	95
8.09	Calculating Measures of Center and Spread	99
8.11	Predicting Population Using Sample Data	103

Contents **Mini-Lessons** (continued)

Prerequisite Skills and Concepts	107
MA.4.GR.2.1 Solving Problems Involving Area and Perimeter	109
MA.4.GR.1.1 Identifying Acute, Obtuse, Right, and Straight Angles	113
MA.5.GR.3.1 Using the Structure of Rectangular Prisms to Determine Volume	117
MA.5.GR.3.3 Using Clues to Determine the Volumes of Figures	121
MA.5.NSO.2.1 Finding Products Using the Standard Algorithm With Composing in More Than One Place	125
MA.5.NSO.2.3 Adding Decimals	129
MA.5.NSO.2.3 Adding and Subtracting Decimals	133
MA.5.NSO.2.5 Multiplying Decimals Less Than 1	137
MA.5.NSO.2.5 Multiplying Two Decimals Greater Than 1	141
MA.6.AR.2.2 Writing and Solving Equations	145
MA.6.NSO.1.1 Ordering and Comparing Positive and Negative Numbers	149
MA.6.NSO.4.1 Adding and Subtracting Positive and Negative Numbers	153
MA.6.NSO.4.1 Solving Real-World Problems Involving Positive and Negative Numbers	157

Contents

Extensions

Unit 1 Scale Drawings	163
Sub-Unit 1: Scaled Copies	165
Sub-Unit 2: Scale Drawings	169
Unit 2 Introducing Proportional Relationships	173
Sub-Unit 1: Proportional Relationships in Tables	175
Sub-Unit 2: Proportional Relationships in Equations	179
Sub-Unit 3: Proportional Relationships in Graphs	183
Sub-Unit 4: Using Proportional Relationships	186
Unit 3 Measuring Circles	189
Sub-Unit 1: Circumference of a Circle	191
Sub-Unit 2: Area of a Circle	195
Unit 4 Proportional Relationships and Percentages	199
Sub-Unit 1: Percentages as Proportional Relationships	201
Sub-Unit 2: Applying Percentages	205
Sub-Unit 3: Proportional Relationships with Fractions and Decimals	209
Unit 5 Positive and Negative Rational Numbers	213
Sub-Unit 1: Adding and Subtracting	215
Sub-Unit 2: Multiplying and Dividing	219
Unit 6 Expressions, Equations, and Inequalities	223
Sub-Unit 1: Equations and Tape Diagrams	225
Sub-Unit 2: Solving Equations	229
Sub-Unit 3: Inequalities	233

Contents

Extensions

(continued)

Unit 7 Polygons and Cylinders 237

Sub-Unit 1: Calculating Areas of Complex Shapes 239

Sub-Unit 2: Volume 243

Unit 8 Probability and Sampling 247

Sub-Unit 1: Probability 249

Sub-Unit 2: Sampling 253

Intervention and Extension

Amplify Desmos Math Florida provides a comprehensive suite of intervention and extension resources designed to meet the needs of all students and are intended to be used outside of the core lesson.

Assess and Respond: After the Lesson

Each lesson has a formative assessment called a **Show What You Know**. This assessment illustrates students' progress toward key concepts in the lesson and is accompanied by a table with suggestions in three categories: students who need **support**, students who would benefit from more practice to **strengthen** their understanding, and students who are interested in a **stretch** to deepen their understanding.

S Support

Provide targeted intervention for students.

S Strengthen

Reinforce students' understanding of the concepts assessed.

S Stretch

Challenge students and extend their learning.

Differentiation Resources

The differentiation resources provide *beyond-the-lesson* support and challenge for all students.

Support, **Strengthen**, and **Stretch** print resources include:

- **Mini-Lessons:** Targeted intervention lessons to support students with a specific concept or skill.
- **Lesson Practices:** Practices to build and reinforce students' conceptual understanding, fluency, and application. Lesson Practices include fluency, test prep, and spiral review.
- **Extensions:** Problems aligned to the math of the sub-unit, designed for students who want to extend their thinking.

The differentiation table is available on the *Show What You Know* page of the Teacher Edition and in the *Differentiation Beyond the Lesson* tab of each lesson.

The screenshot shows the 'Show What You Know' assessment interface. At the top, it indicates 'Independent' and '5 min'. The purpose is for students to demonstrate understanding by calculating the area of a scaled rectangle. Below this, 'Today's Goals' are listed: 1. Calculate the area of a scaled copy, and 2. Explain how scaling affects length and area in scaled copies. A 'Show What You Know (Assessment Resources)' section shows a grid with a rectangle. Below the assessment, a 'Differentiation' section is visible, with tabs for 'Support', 'Stretch', and 'Professional Learning'. The 'Support' tab provides targeted intervention resources, while the 'Stretch' tab offers challenges. The 'Professional Learning' section encourages reflection on the instructional routine.

Differentiation Beyond the Lesson table from
Grade 7, Unit 1, Lesson 5.

Assess and Respond: After Unit Assessments

Embedded unit assessments offer key insights into students' understanding of the grade-level standards in the unit.

- Each unit includes an optional Pre-Unit Check, one or more Sub-Unit Quizzes, and an End-of-Unit Assessment.
- Each assessment is accompanied by an Assess and Respond Guide in the Teacher Edition, which includes responses to student thinking with resources that support, strengthen, and stretch learning.

Sub-Unit Quiz

1. To respond to student thinking, consider:

Sub-Unit Goals	Problem(s)	To respond to student thinking, consider:
Sub-Unit 1: <ul style="list-style-type: none"> Describe how scaling affects lengths, angles, and areas in scaled copies. Use scale factors to create and compare scaled copies. (Lessons 1-9) 	1.4b	Support • Teacher Move: Consider revisiting Unit 1, Lesson 1 (Scaling Machines) and Unit 1, Lesson 4 (Scale Factor Challenges)
		Strengthen • Practicing With Scale Factors: Lesson 4 (Scale Factor Challenges)
	Stretch • You're invited to explore more: Lesson 3 (Make It Scale)	
	3	Support • Mini-Lesson: Connecting Scale Factors to Scaled Copies (ML 1.04)
		Strengthen • Teacher Move: Consider asking, "Which side measurements should be used to determine a scale factor between two figures?"
	Stretch • You're invited to explore more: Lesson 4 (Scale Factor Challenges)	
2.4a, 5	Support • Teacher Move: Consider revisiting Unit 1, Lesson 3 (Make It Scale) and Unit 1, Lesson 5 (Class)	
	Strengthen • Teacher Move: Consider asking, "How does scaling impact the area of a scaled copy? How does it impact the side length?"	
Stretch • You're invited to explore more: Lesson 5 (Back in My Day)		

Unit 1 41B Assess and Respond

Sub-Unit Quiz Differentiation table from Grade 7, Unit 1, Sub-Unit 1.

About Mini-Lessons

Amplify Desmos Math Florida Mini-Lessons are print activities aligned to the most critical content and skills in corresponding core lessons.



Mini-Lessons offer direct instruction and guided practice opportunities. These Mini-Lessons complement the problem-based approach, are ideal for small-group or whole-class instruction, as well as independent learning.

Student Page

Amplify Desmos Math Florida Mini-Lessons are designed based on extensive research around worked examples.¹

The Student Page is organized to follow the flow of the Mini-Lesson: **Modeled Review**, **Guided Practice**, and **Check**.

Grade 7, Unit 1, Lesson 10 Mini-Lesson

- 1 Modeled Review:** A worked example designed to be discussed as a group. Students make sense of a concept or process by examining the modeled student thinking.
- 2 Guided Practice:** A series of problems that fades away scaffolding as students progress. Teachers can approach the Guided Practice in various ways based on their expertise and understanding of their students' needs.
- 3 Check:** An opportunity for students to show what they've learned. We recommend all students complete this independently.

Considerations:

- Print or copy the Student Page in advance.
- Gather any needed materials. Any materials listed as optional on the Teacher Guide are not required to successfully implement the lesson.
- It may be helpful to have a whiteboard, but it's not required.

¹ Flores, R. and Inan, F. (2014). Examining the Impact of Adaptively Faded Worked Examples on Student Learning Outcomes. *Journal of Interactive Learning Research*, 467–485.

Teacher Guide

The Teacher Guide follows the same flow as the Student Page, with all the information needed to implement the Mini-Lesson.

ML 1.10 **Determining Unknowns in Scale Drawings**

Goal
Calculate distances on a scale drawing, given a drawing of the same object with a different scale.

Standard
MA.7.GR.1.5

Modeled Review
Point to Han's work and ask:
• "What does one unit represent in each drawing?"
• "How does the large drawing help you determine the scale of the small drawing?"
Reinforce Han's thinking by saying, "You can use the large drawing to calculate the actual height of the building. Use that height to help you determine the corresponding lengths in the smaller drawing."
• Invite students to articulate or label the scale drawings to help them make sense of the scale.

Guided Practice
Focus students' attention on finding the actual heights, the scale drawing height, and the scale.
To scaffold their thinking, ask:
• "What is the height of this building?"
• "What is the height of the scale drawing?"
• "How can you use both of those to find the scale?"

Reflection
Ask
• "What information from an original scale model is helpful in determining the scale for a new model?"
• "What makes sense? What is still confusing?"

Check: Recommended Next Steps
Almost there
If students need more support, consider reviewing the concept of proportional relationships and how they apply to scale drawings. Emphasize that corresponding lengths in the scale drawing are proportional to the actual object.
Got it!
If students need more practice, have them repeat Problems 3–4 and provide a different height or scale.

Grade 7, Unit 1, Lesson 10 Mini-Lesson

Every Teacher Guide includes:

- The **lesson goal, materials**, and relevant **vocabulary terms**.
- Questions or statements to share with students in each part of the Mini-Lesson. **Reflection questions** are included as a way to close out the lesson.
- **Answer keys** with sample responses on the insets of the student pages.
- **Recommended next steps** for students needing more support or extra practice based on their performance on the Check problem(s).

Supporting All Learners

- ELL** This icon indicates suggestions for supporting **English Language Learners**.
- A** This icon appears at point-of-use and indicates suggestions for supporting the needs of all learners, based on the guidelines of **Universal Design for Learning (UDL)**.

Lesson and Mini-Lesson Alignment

Show What You Know **ML 1.10**

Here are two scale drawings of the Hagia Sophia in Istanbul, Turkey.
Complete the scale. What is the unknown value in the scale?
Explain your thinking.

Determining Unknowns in Scale Drawings **ML 1.10**

Modeled Review
Here are two scale drawings of the same building. How many meters does the unknown scale represent? Show your thinking.

Height	Scale
11 · 5 = 55	$\frac{11}{55} = \frac{1}{11}$
55 meters	11 meters

The building in both the small and large drawing is 55 meters tall. The large drawing's scale is 1 centimeter represents 10 meters, so the small drawing's scale is 1 unit represents 5 meters.

Guided Practice
Complete the scale for each building by determining the unknown measurement. Show your thinking.

1. building height: _____ meters
scaled drawing height: 8 units
_____ meters = _____ meters
Scale = _____ meters

2. building height: _____ feet
scaled drawing height: _____ units
_____ meters = _____ meters
Scale = _____ meters

Grade 7, Unit 1, Lesson 10 SWYK and Mini-Lesson

Mini-Lessons are closely aligned to the core lesson they are connected to. The **Mini-Lesson Modeled Review** is built using the *Show What You Know* (SWYK) from the lesson. Teachers can use student thinking on the *Show What You Know* to identify students who might benefit from the extra support of a Mini-Lesson.

About Extensions

Amplify Desmos Math Florida Extensions are sets of problems aligned to the math of the sub-unit. They are useful for students interested in an additional challenge or for the whole class.



Extensions build on our **student-led, problem-based** approach because they provide more opportunities for students to engage in creative and rigorous problems that can be approached using different strategies.

Student Page

Every sub-unit includes an Extensions problem set.

They are print-based, hands-on problems structured on the principle of student choice and designed to be student-led. The math is designed to be accessible to students at any time they are ready for more during the sub-unit.

Every sub-unit Extension includes:

- **Challenge:** Extensions focus on problem-solving and sharing thinking rather than answer-getting, with problems aligned to the math in the sub-unit.
- **Choice:** Extensions contain multiple open-ended problems, and students can start with what interests them.
- **Variety:** Some problems are designed with hands-on materials, others are discussion-based, and the rest require only a pencil and paper.

Considerations:

- Invite students to choose one problem to focus on at a time.
- Prepare enough Extensions at the start of the sub-unit for all students so you can be flexible with when different students work on them.
- Think about where you will want students to store their work on the Extensions for the duration of the sub-unit.

Unit 1
Sub-Unit 1
Extensions

Scaled Copies

Name: _____ Date: _____ Period: _____

Student Choice Start with any problem. Remember to show or explain your thinking.

1 Remove eight toothpicks from the given design to create two squares.

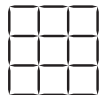

2 Eight identical rectangles form a larger rectangle, as shown in the figure. Suppose you know that the length and width of the smaller rectangles are whole numbers, and the area of the larger rectangle is 480 square feet. Determine the perimeter of the larger rectangle.



165

Grade 7, Unit 1, Sub-Unit 1 Extension Student Page

Teacher Guide

Extensions are designed to be a light lift for the teacher.

Every sub-unit Extension Teacher Guide includes:

- **Key background information** about the math in the problem.
- **Suggestions** for which problems to share with the whole class if time allows.
- **Hints** to share with students when needed.
- **Sample responses.**

Considerations:

- Look for opportunities to introduce an Extension problem with the whole class early in the sub-unit so all students can participate.
- Help students get started on the Extension task, then let them work independently or in pairs while you work with other groups of students who may benefit from more direct support from a teacher.

Unit 1
Sub-Unit 1
Extensions **Scaled Copies**

Assign problems to students who want to extend their thinking. Problems 1, 2, and 3 can be solved in any order. If time allows, consider sharing Problem 3 with all students.

Materials
• toothpicks (optional) (Problem 1)
• graph paper (optional) (Problem 3)

Problem 1
Students will extend their understanding of objects that are scaled copies of one another by solving the toothpick puzzle.
Provide students with the following hint if additional scaffolding is needed.
• Hint: You can use toothpicks to help you visualize the puzzle better.

Responses vary.

Problem 2
Students will extend their understanding of identical shapes, ratios, and both perimeter and area calculations by solving this problem.
Provide students with the following hint if additional scaffolding is needed.
• Hint: If you were to redraw this shape on grid paper, how would you arrange the length and width of the small rectangles so that three times the length would be the same as five times the width?

92 feet. Explanations vary. I labeled the width of the small rectangle a and the length b . The top and bottom of the rectangle are the same length, so I know that $3b = 5a$.

8 rectangles fit in the area of the larger rectangle, so the area of each small rectangle is $480 \div 8 = 60$ sq. feet. I checked all the pairs of numbers with a product of 60, and the only pair that makes $3b = 5a$ is $a = 6$ and $b = 10$. So, the perimeter of the larger rectangle is $2 \cdot 5 \cdot 6 + 2 \cdot (10 \cdot 6) = 92$ feet.

Grade 7 167

Grade 7, Unit 1, Sub-Unit 1 Extension Teacher Guide

Lesson and Extension Alignment

Sub-unit
1 **Scaled Copies**

Lesson 1
Scaling Machines

Lesson 4
Scale Factor Challenges

Unit 1
Sub-Unit 1
Extensions **Scaled Copies**

Name _____ Date _____ Period _____

Student Choice Start with any problem. Remember to show or explain your thinking.

1 Remove eight toothpicks from the given design to create two squares.

2 Eight identical rectangles form a larger rectangle, as shown in the figure. Suppose you know that the length and width of the smaller rectangles are whole numbers, and the area of the larger rectangle is 480 square feet. Determine the perimeter of the larger rectangle.

165

Grade 7, Unit 1, Sub-Unit 2 Opener and Extension

Extensions are aligned to the math of the **sub-unit**, but they also go deeper. The problems in Extensions are designed to make connections between the math of the sub-unit and other concepts. In some cases, problems will involve content from prior grades or units.



Mini-Lessons

Unit 1

Mini-Lessons

Connecting Scale Factors to Scaled Copies

ML 1.04



Modeled Review



Name: Shawn

What scale factor takes the original rectangle to its scaled copy? Show or explain your reasoning.

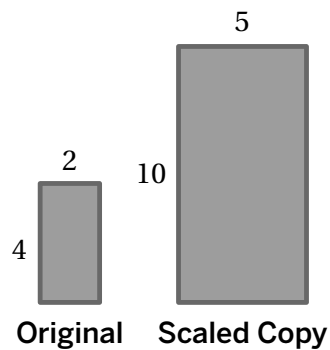

$$\frac{\text{new length}}{\text{original length}} = \frac{5}{2} \text{ or } \frac{10}{4}$$

$\frac{5}{2}$ is the scale factor.



Guided Practice



- Each original robot has a scaled copy. Complete the table by using the corresponding side lengths to determine the scale factor.

Original	Scaled copy	Ratio = $\frac{\text{New Length}}{\text{Original Length}}$	Scale factor
		$\frac{15}{5}$ or $\frac{24}{8}$	
		$\frac{\square}{\square}$ or $\frac{\square}{\square}$	



Guided Practice



2. For each pair of objects, determine the scale factor that takes the original to the scaled copy.

Original	Scaled copy	Scale factor
<p>Original hot air balloon with height 15 and width 9.</p>	<p>Scaled hot air balloon with height 30 and width 18.</p>	
<p>Original hot air balloon with height 30 and width 18.</p>	<p>Scaled hot air balloon with height 15 and width 9.</p>	
<p>Original truck with height 3 and width 4.</p>	<p>Scaled truck with height 7.5 and width 10.</p>	



Check



What scale factor takes the original to the scaled copy?

Original	Scaled copy	Scale factor
<p>Original right triangle with vertical side 20 and horizontal side 15.</p>	<p>Scaled right triangle with vertical side 12 and horizontal side 9.</p>	

Goal

Determine scale factors using corresponding side lengths.

Standard

MA.7.GR.1.5



Modeled Review

Point to Shawn's work and ask:

- "Which sides correspond between the original and the scaled copy?"
- "How do the ratios of corresponding measurements help to determine the scale factor?"
- "Why is the scale factor $\frac{5}{2}$ and not $\frac{2}{5}$?"
- "Why is the scale factor $\frac{5}{2}$ or $\frac{10}{4}$? How are these fractions related?"

Reinforce the goal by saying, "Scaling an object requires scaling all dimensions."



Guided Practice

Focus students' attention on dividing the new length by the original length when setting up the ratio of corresponding measurements.

To scaffold their thinking, ask:

- "What are the corresponding sides of the original and the scaled copy?"
- "How do the ratios of corresponding measurements help to determine the scale factor?"
- "How do you determine the scale factor?"

Name _____

Connecting Scale Factors to Scaled Copies

ML 1.04



Modeled Review

Name: Shawn

What scale factor takes the original rectangle to its scaled copy? Show or explain your reasoning.

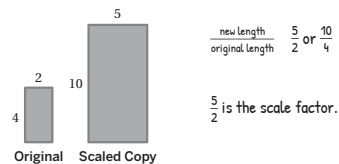

Guided Practice

- Each original robot has a scaled copy. Complete the table by using the corresponding side lengths to determine the scale factor. **Sample responses shown.**

Original	Scaled copy	Ratio = $\frac{\text{New Length}}{\text{Original Length}}$	Scale factor
		$\frac{15}{5}$ or $\frac{24}{8}$	3 or equivalent
		$\frac{2}{8}$ or $\frac{3}{12}$	$\frac{1}{4}$ or equivalent

5

© Amplify Education, Inc. and its licensors.

Vocabulary

If needed, share the meaning of the terms with students.

scale factor: The number that all side lengths are multiplied by to create a scaled copy.

scaled copy: A copy of a figure where every length in the original figure is multiplied by the same number.



Guided Practice

A If needed, model identifying the corresponding side lengths and determining the scale factor.

Key Takeaway:

Say, “The size of the scale factor affects the size of the scaled copy. If the scale factor is greater than 1, the scaled copy will be larger than the original figure. If the scale factor is between 0 and 1, the scaled copy will be smaller than the original figure. If the scale factor is equal to 1, the scaled copy will be the same size as the original figure.”



Guided Practice

2. For each pair of objects, determine the scale factor that takes the original to the scaled copy.

Original	Scaled copy	Scale factor
		2 or equivalent
		$\frac{1}{2}$ or equivalent
		$\frac{5}{2}$ or equivalent



Check

What scale factor takes the original to the scaled copy?

Original	Scaled copy	Scale factor
		$\frac{3}{5}$ or equivalent

Reflection

Ask:

- “What do you notice about the scale factor as the original image gets larger? Smaller?”
- “What is something you weren't sure about at the start of the lesson but understand now?”



Check: Recommended Next Steps

Almost there

If students need more support, consider modeling step-by-step how to determine the scale factor using corresponding side lengths. Break down each step and explain the reasoning behind each calculation.

Got it!

If students need more practice, sketch the following figures. Ask them to determine the scale factor that takes Figure A to Figure B and then takes Figure B to Figure A.

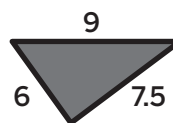

Figure A

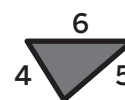

Figure B

Determining Unknowns in Scale Drawings

ML 1.10



Modeled Review



Name: Han

Here are two scale drawings of the same building. How many meters does the unknown scale represent? Show your thinking.

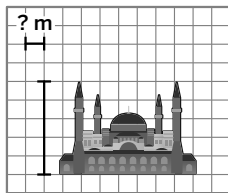

$$1 \text{ unit} = 5 \text{ meters}$$

Height

Scale

$$11 \cdot 5 = 55$$

$$\frac{55}{5} = 11$$

55 meters

11 meters

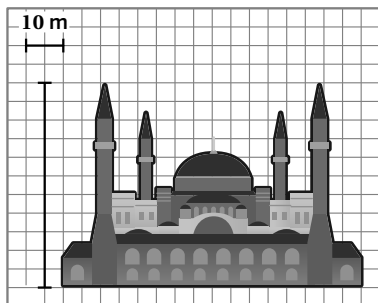

The building in both the small and large drawing is 55 meters tall. The large drawing's scale is 2 units represents 10 meters, so the small drawing's scale is 1 unit represents 5 meters.



Guided Practice



Complete the scale for each building by determining the unknown measurement. Show your thinking.

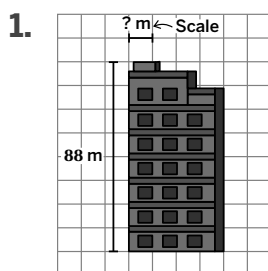

building height: _____ meters

scaled drawing height: 8 units

_____ meters = _____

8 units

Scale = _____ meters

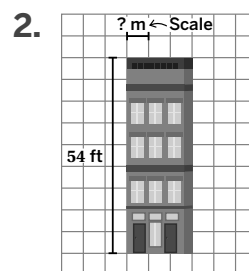

building height: _____ feet

scaled drawing height: _____ units

_____ = _____

Scale = _____



Guided Practice



For Problems 3-4, use the two scale drawings of the same building. How many feet does the unknown scale represent?

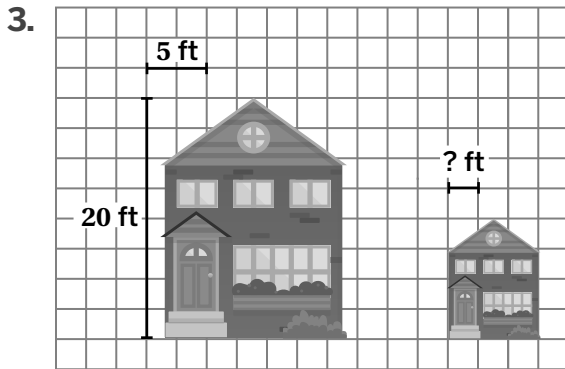

unknown scale = _____ feet per unit
Height Scale

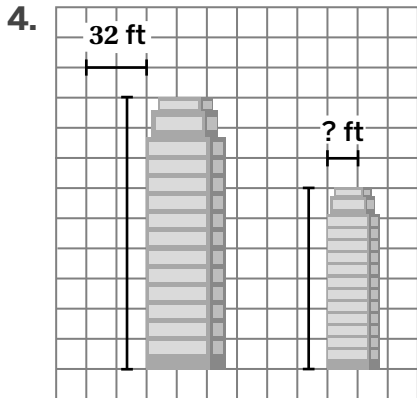

unknown scale = _____



Check



Here are two scale drawings of an apartment building. How many meters does the unknown scale represent? Show your thinking.

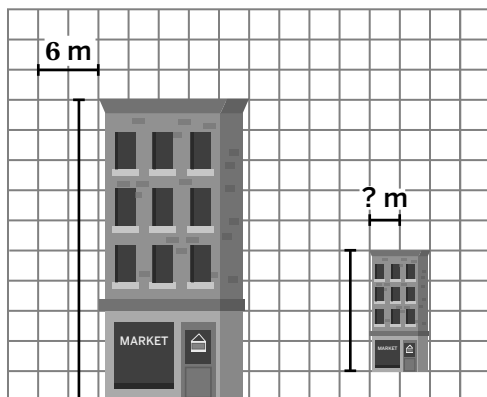

unknown scale = _____

Goal

Calculate distances on a scale drawing, given a drawing of the same object with a different scale.

Standard

MA.7.GR.1.5

Modeled Review

- Point to Han's work and **ask**:
- "What does one unit represent in each drawing?"
 - "How does the large drawing help you determine the scale of the small drawing?"

Reinforce Han's thinking by saying, "You can use the large drawing to calculate the actual height of the building. Use that height to help you determine the corresponding lengths in the smaller drawing."

ML/EL Invite students to annotate or label the scale drawings to help them make sense of the scale.

Guided Practice

Focus students' attention on finding the actual height, the scale drawing height, and the scale.

- To scaffold their thinking, **ask**:
- "What is the height of the building?"
 - "What is the height of the scale drawing?"
 - "How can you use both of those to find the scale?"

Name _____

Determining Unknowns in Scale Drawings

ML 1.10

Modeled Review

Here are two scale drawings of the same building. How many meters does the unknown scale represent? Show your thinking.

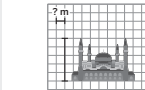

1 unit = 5 meters

Height	Scale
$11 \cdot 5 = 55$	$\frac{55}{5} = 11$
55 meters	11 meters

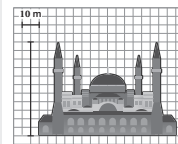

The building in both the small and large drawing is 55 meters tall. The large drawing's scale is 2 units represents 10 meters, so the small drawing's scale is 1 unit represents 5 meters.

Guided Practice

Complete the scale for each building by determining the unknown measurement. Show your thinking.

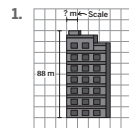

building height: 88 meters
 scaled drawing height: 8 units
88 meters = 11
 8 units
 Scale = 11 meters

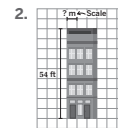

building height: 54 feet
 scaled drawing height: 9 units
54 feet = 6
9 units
 Scale = 6 feet

Vocabulary

If needed, share the meaning of the terms with students.

scale: A scale tells us how the measurements in a scale drawing represent the actual measurements of the object.

scale drawing: A scale drawing represents an actual place or object. All the measurements in the drawing correspond to the measurements of the actual object by the same scale.



Guided Practice

A As students make sense of visual representations, invite them to annotate, label, or draw on the given scale drawings to help them make sense of the scale.

Key Takeaway:

Say, “Different scales can be used to create scale drawings that accurately depict the dimensions of an object. Comparing scales helps determine if a drawing will be smaller than, equivalent to, or larger than another.”



Guided Practice

For Problems 3-4, use the two scale drawings of the same building. How many feet does the unknown scale represent? **Sample work shown.**

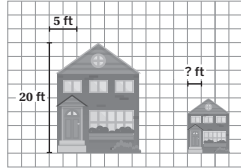
3. 

unknown scale = 5 feet per unit

Height	Scale
20 feet tall	$\frac{20 \text{ feet}}{4 \text{ units}} = 5$

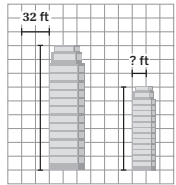
4. 

unknown scale = 24 feet per unit

1 unit = 16 feet	
Height	Scale
$16 \cdot 9 = 144$	$\frac{144 \text{ feet}}{6 \text{ units}} = 24$
144 feet tall	



Check

Here are two scale drawings of an apartment building. How many meters does the unknown scale represent? Show your thinking. **Sample work shown.**

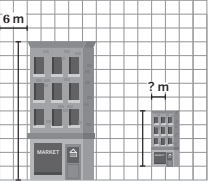

unknown scale = 7.5 meters per unit

1 unit = 3 meters	
Height	Scale
$3 \cdot 10 = 30$	$\frac{30 \text{ meters}}{4 \text{ units}} = 7.5$
30 meters tall	

Reflection

Ask:

- “What information from an original scale model is helpful in determining the scale for a new model?”
- “What makes sense? What is still confusing?”



Check: Recommended Next Steps

Almost there

If students need more support, consider reviewing the concept of proportional relationships and how they apply to scale drawings. Emphasize that corresponding lengths in the scale drawing are proportional to the actual object.

Got it!

If students need more practice, have them revisit Problems 1–4 and provide a different height or scale.

Unit 2

Mini-Lessons

Determining the Constant of Proportionality

ML 2.03



Modeled Review



Name: Clare

Determine the constant of proportionality for the relationship and complete the table. What does the constant of proportionality tell you about the situation?

The constant of proportionality is 5.

The paint is made with 5 cups of yellow paint for every 1 cup of blue paint.
 $2 \cdot 5 = 10$
 $6 \cdot 5 = 30$

Blue paint (cups)		Yellow paint (cups)
2	$\times 5 \rightarrow$	10
1		5
6	$\times 5 \rightarrow$	30
52		260



Guided Practice



Determine the constant of proportionality for the relationship and complete the table.

- $8 \cdot 3 = 24$
 $12 \cdot \underline{\quad} = \underline{\quad}$
 $128 \cdot \underline{\quad} = \underline{\quad}$

The constant of proportionality is _____.

Lemonade

	Volume (oz)	Sugar (g)
glass	8	$\times 3 \rightarrow 24$
bottle	12	
carton	32	96
jug	128	

- $8 \cdot \underline{\quad} = \underline{\quad}$
 $12 \cdot \underline{\quad} = \underline{\quad}$
 $128 \cdot \underline{\quad} = \underline{\quad}$

The constant of proportionality _____.

Apple juice

	Volume (oz)	Sugar (g)
glass	8	
bottle	12	
carton	32	80
jug	128	



Guided Practice



Determine the constant of proportionality for the relationship and complete the table. What does the constant of proportionality tell you about the situation?

3. The constant of proportionality is _____.

The paint is made with _____ cups of blue paint for every _____ cup of red paint.

Red paint (cups)	Blue paint (cups)
2	3
1	
6	
40	60

4. The constant of proportionality is _____.

Red paint (cups)	Yellow paint (cups)
2	8
1	
	32
50	



Check



Determine the constant of proportionality for the relationship and complete the table. What does the constant of proportionality tell you about the situation?

White paint (cups)	Red paint (cups)
2	4
1	
7	
	80

Goal

Determine the constant of proportionality for a proportional relationship.

Standard

MA.7.AR.4.1

Materials

calculators (optional)



Modeled Review

Point to Clare's work and **ask**:

- "What did Clare do to find the constant of proportionality?"
- "How did Clare use the constant of proportionality to find the missing values?"

Reinforce the goal by saying, "When a table shows a proportional relationship, the values in one column can be multiplied by the same number, the constant of proportionality, to get the values in the other column."



Guided Practice

Focus students' attention on using the table to determine the constant of proportionality.

To scaffold their thinking, **ask**:

- "How could you determine the constant of proportionality?"
- "How does the constant of proportionality help you determine the missing values?"

Name _____

Determining the Constant of Proportionality

ML 2.03

Modeled Review

Name: Clare

Determine the constant of proportionality for the relationship and complete the table. What does the constant of proportionality tell you about the situation?

The constant of proportionality is 5.

The paint is made with 5 cups of yellow paint for every 1 cup of blue paint. $2 \cdot 5 = 10$
 $6 \cdot 5 = 30$

Blue paint (cups)	Yellow paint (cups)
2	10
1	5
6	30
52	260

Guided Practice

Determine the constant of proportionality for the relationship and complete the table.

- $8 \cdot 3 = 24$
 $12 \cdot 3 = 36$
 $128 \cdot 3 = 384$

The constant of proportionality is 3.

	Lemonade	
	Volume (oz)	Sugar (g)
glass	8	24
bottle	12	36
carton	32	96
jug	128	384

- $8 \cdot 2.5 = 20$
 $12 \cdot 2.5 = 30$
 $128 \cdot 2.5 = 320$

The constant of proportionality is 2.5.

	Apple juice	
	Volume (oz)	Sugar (g)
glass	8	20
bottle	12	30
carton	32	80
jug	128	320

Vocabulary

If needed, share the meaning of the term with students.

constant of proportionality: A number that the value of one quantity is multiplied by to get the value of the other quantity in a proportional relationship.



Guided Practice

A As students identify patterns and relationships, invite them to annotate the tables to show how to obtain each value using multiplication and the constant of proportionality.

ML/EL Provide sentence frames to help students explain their strategy such as:

- “I know the paint is the same color because___.”
- “I determined the missing paint amounts by___.”

Key Takeaway:

Say, “In a proportional relationship, the values for one quantity are multiplied by the same number to obtain the values for the other quantity. This number is called the constant of proportionality.”



Guided Practice

Determine the constant of proportionality for the relationship and complete the table. What does the constant of proportionality tell you about the situation? **Sample response shown for Problem 4.**

3. The constant of proportionality is 1.5.

The paint is made with 1.5 cups of blue paint for every 1 cup of red paint.

Red paint (cups)	Blue paint (cups)
2	3
1	1.5
6	9
40	60

4. The constant of proportionality is 4.

The paint is made with **4 cups of yellow paint for every 1 cup of red paint.**

Red paint (cups)	Yellow paint (cups)
2	8
1	4
8	32
50	200



Check

Determine the constant of proportionality for the relationship and complete the table. What does the constant of proportionality tell you about the situation? **Sample response shown.**

The constant of proportionality is **2**.

The paint is made with **2 cups of red paint for every 1 cup of white paint.**

White paint (cups)	Red paint (cups)
2	4
1	2
7	14
40	80

Reflection

Ask:

- “How do you use the constant of proportionality to find missing values?”
- “How does what you learned today connect to your prior learning?”



Check: Recommended Next Steps

Almost there

If students need more support, explain that the constant of proportionality can also be found by dividing the value in the second column by the corresponding value in the first column.

Got it!

If students need more practice, have them revisit Problem 3 and continue completing the table to determine how much blue paint would be needed if the amount of the red paint is:

- 10 cups
- 15 cups
- 30 cups
- 100 cups

Finding More Than One Equation to Represent Proportional Relationships

ML 2.06



Modeled Review

Name: Jason

A car traveled 150 miles in 2 hours at a constant speed.

1. What are two constants of proportionality for the relationship between distance in miles, d , and number of hours, t , that the car traveled?

$$\frac{150}{2} \text{ and } \frac{2}{150}$$

2. Write two equations that relate d and t in this situation.

$$d = \frac{150}{2}t \text{ and } t = \frac{2}{150}d$$



Guided Practice



Complete the table and determine the constant of proportionality. Write an equation to represent the situation.

1.

x	y
1	
2	10
4	
t	$5t$

constant of proportionality: _____

equation: _____

2.

x	y
1	
4	
8	
w	$\frac{1}{4}w$

constant of proportionality: _____

equation: _____



Guided Practice



There are 400 centimeters in every 4 meters.

- Determine two constants of proportionality for the relationship between meters, x , and centimeters, y .
- Write two equations that relate x and y in this situation.

It took 6 minutes, t , to fill a cooler with 8 gallons of water, w , at a steady rate.

- Determine two constants of proportionality for the relationship between time, t , and gallons of water, w .
- Write two equations that relate t and w in this situation.



Check



A polar bear swam 426 miles across the Beaufort Sea, north of Alaska, in 9 days.

- Determine two constants of proportionality for the relationship between distance in miles, d , and number of days, t , that the polar bear swam.
- Write two equations that relate d and t in this situation.

Goal

Determine the constant of proportionality for a proportional relationship.

Standard

MA.7.AR.4.4

Materials

calculators (optional)



Modeled Review

Point to Jason's work and ask:

- "Why are you able to write two equations for any proportional relationship?"
- "How are the constants of proportionality related in the two equations?"

Reinforce Jason's thinking by saying, "Two equations can be used to represent a proportional relationship by using the reciprocal."

ML/EL Have students give examples of pairs of numbers that are reciprocals to formalize new vocabulary.



Guided Practice

Focus students' attention on writing an equation for the given proportional relationship.

To scaffold their thinking, **ask**:

- "How did you find an equation for each table?"
- "Where do you see the constant of proportionality in the table and in the equation?"
- "How are Problems 1 and 2 similar? Different?"

Name _____

Finding More Than One Equation to Represent Proportional Relationships

ML 2.06



Modeled Review



Name: Jason

A car traveled 150 miles in 2 hours at a constant speed.

1. What are two constants of proportionality for the relationship between distance in miles, d , and number of hours, t , that the car traveled?

$$\frac{150}{2} \text{ and } \frac{2}{150}$$

2. Write two equations that relate d and t in this situation.

$$d = \frac{150}{2}t \text{ and } t = \frac{2}{150}d$$



Guided Practice



Complete the table and determine the constant of proportionality. Write an equation to represent the situation.

1.

x	y
1	5
2	10
4	20
t	$5t$

2.

x	y
1	$\frac{1}{4}$
4	1
8	2
w	$\frac{1}{4}w$

constant of proportionality: 5

equation: $y = 5x$

constant of proportionality: $\frac{1}{4}$

equation: $y = \frac{1}{4}x$

Vocabulary

If needed, share the meaning of the term with students.

reciprocal: Two numbers whose product is 1.



Guided Practice

A To support organization in problem solving, chunk this activity into more manageable parts by inviting students to generate one constant of proportionality and/or equation at a time. Then have them compare the reciprocal.

Note: If students need additional support, consider asking:

- “What is the relationship between the two constants of proportionality?”
- “How could determining one equation help you to determine another equation to describe the relationship?”

Key Takeaway:

Say, “For every proportional relationship, there are two constants of proportionality that are reciprocals of each other, and two equations that can be written to represent each proportional relationship.”



Guided Practice

There are 400 centimeters in every 4 meters. **Sample responses shown.**

3. Determine two constants of proportionality for the relationship between meters, x , and centimeters, y .

$$\frac{400}{4} \text{ (or equivalent) and } \frac{4}{400} \text{ (or equivalent)}$$

4. Write two equations that relate x and y in this situation.

$$y = \frac{400}{4}x \text{ (or equivalent) and } x = \frac{4}{400}y \text{ (or equivalent)}$$

It took 6 minutes, t , to fill a cooler with 8 gallons of water, w , at a steady rate. **Sample responses shown.**

5. Determine two constants of proportionality for the relationship between time, t , and gallons of water, w .

$$\frac{6}{8} \text{ (or equivalent) and } \frac{8}{6} \text{ (or equivalent)}$$

6. Write two equations that relate t and w in this situation.

$$t = \frac{6}{8}w \text{ (or equivalent) and } w = \frac{8}{6}t \text{ (or equivalent)}$$



Check

A polar bear swam 426 miles across the Beaufort Sea, north of Alaska, in 9 days. **Sample responses shown.**

1. Determine two constants of proportionality for the relationship between distance in miles, d , and number of days, t , that the polar bear swam.

$$\frac{426}{9} \text{ (or equivalent) and } \frac{9}{426} \text{ (or equivalent)}$$

2. Write two equations that relate d and t in this situation.

$$d = \frac{426}{9}t \text{ (or equivalent) and } t = \frac{9}{426}d \text{ (or equivalent)}$$

Reflection

Ask:

- “What is the biggest takeaway you have from this lesson?”
- “What questions do you still have after this lesson?”



Check: Recommended Next Steps

Almost there

If students need more support, model and explain how multiplying by the reciprocal can be used to simplify the process of dividing fractions to create the second equation.

Got it!

If students need more practice, present them with the following problem. Have them determine the constants of proportionality and equations to represent the situation.

- A truck driving 480 miles, d , in 7 hours, t .
- A dog running 1600 feet, d , in 2 minutes, t .

Comparing Proportional Relationships With Graphs

ML 2.10



Modeled Review



Name: Gabriela

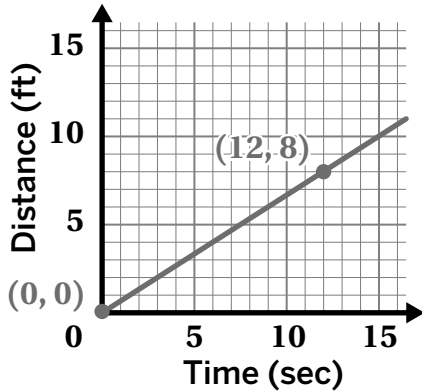

This line represents a proportional relationship because it begins at the origin. Its constant of proportionality is $\frac{8}{12}$ or $\frac{2}{3}$. The equation for the line is $y = \frac{2}{3}x$.



Guided Practice



1. A red turtle moves 10 feet in 5 seconds.

Its speed is 2 ft/sec. Equation: $y = 2x$

A blue turtle moves _____ feet in _____ seconds.

Its speed is $\frac{3}{4}$ ft/sec. Equation: $y = \frac{3}{4}x$

Which turtle moves *faster*? How do you know?

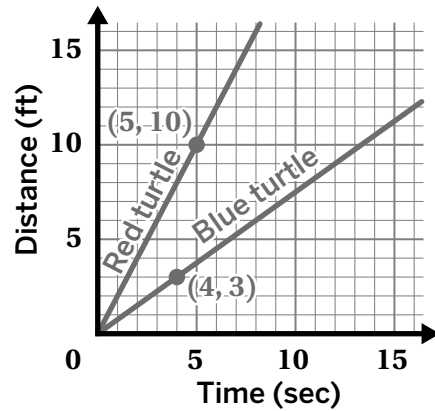

2. A red turtle moves _____ feet in _____ seconds.

Its speed is _____ ft/sec. Equation: $y = \frac{5}{6}x$

A blue turtle moves _____ feet in _____ seconds.

Its speed is _____ ft/sec. Equation: $y = \frac{3}{2}x$

Which turtle moves *slower*? How do you know?

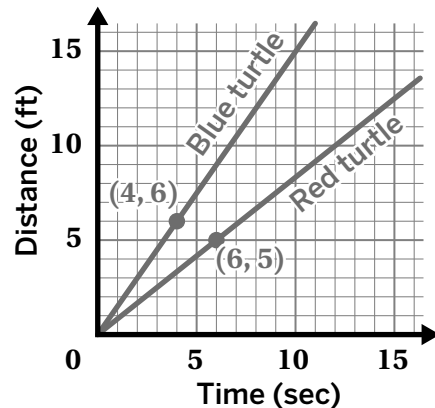



Guided Practice



3. A red turtle moves ____ feet in ____ seconds.
Its speed is ____ ft/sec. Equation: _____
- A blue turtle moves ____ feet in ____ seconds.
Its speed is ____ ft/sec. Equation: _____
- Which turtle moves *slower*? How do you know?

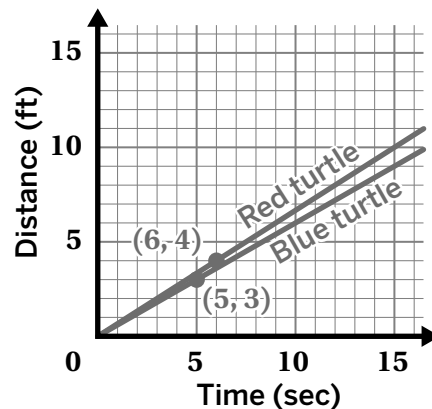

4. A red turtle moves according to the equation $y = 2x$, where y represents the distance in feet and x represents the time in seconds.

Here is a graph that shows the distance a blue turtle moves over time.

Which turtle moves *faster*? How do you know?

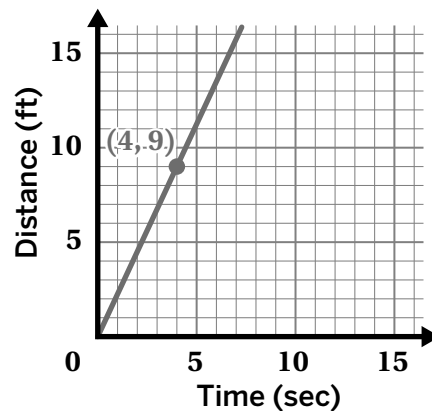

Check



Here is a graph that shows the distance three turtles move over time.

1. Which turtle moves the *fastest*? How do you know?

2. Write an equation for the turtle represented by the green line.

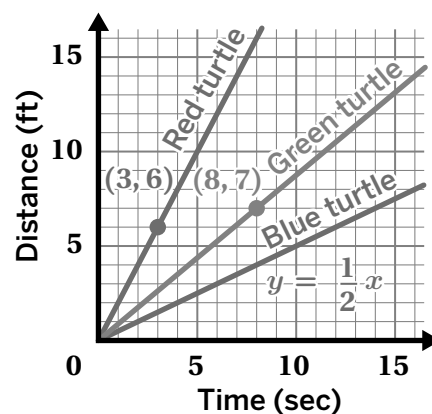

Goal

Use constants of proportionality (as determined using points or equations) or graphs to compare proportional relationships.

Standard

MA.7.AR.4.3

Materials

graph paper (optional)



Modeled Review

Point to Gabriela's work and ask:

- "How did Gabriela calculate the constant of proportionality?"
- "How did Gabriela determine the equation for the line?"
- "How do you know this line and equation show a proportional relationship?"

Reinforce Gabriela's thinking by saying, "Graphs and equations can be used to identify and compare proportional relationships."



Guided Practice

Focus students' attention on calculating the constant of proportionality and using the it to compare the speeds of the turtles.

To scaffold their thinking, ask:

- "What do you need to multiply the time by to calculate the distance?"
- "How could you determine the equation for a proportional relationship using the constant of proportionality?"

Name _____

Comparing Proportional Relationships With Graphs

ML 2.10

Modeled Review

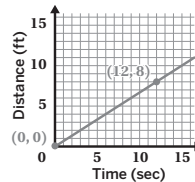

Name: Gabriela
 This line represents a proportional relationship because it begins at the origin. Its constant of proportionality is $\frac{8}{12}$ or $\frac{2}{3}$. The equation for the line is $y = \frac{2}{3}x$.

Guided Practice

1. A red turtle moves 10 feet in 5 seconds.
 Its speed is 2 ft/sec. Equation: $y = 2x$
 A blue turtle moves 3 feet in 4 seconds.
 Its speed is $\frac{3}{4}$ ft/sec. Equation: $y = \frac{3}{4}x$
 Which turtle moves faster? How do you know?

The red turtle because it has a steeper line.

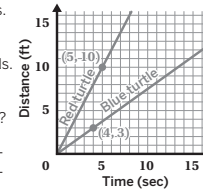

2. A red turtle moves 5 feet in 6 seconds.
 Its speed is $\frac{5}{6}$ ft/sec. Equation: $y = \frac{5}{6}x$
 A blue turtle moves 6 feet in 4 seconds.
 Its speed is $\frac{3}{2}$ ft/sec. Equation: $y = \frac{3}{2}x$
 Which turtle moves slower? How do you know?

The red turtle. Its line is less steep.

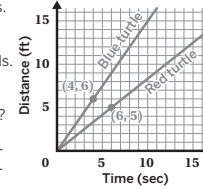

Vocabulary

If needed, share the meaning of the term with students.

proportional relationship: A proportional relationship is a set of equivalent ratios. The values for one quantity are each multiplied by the same number to get the value for the other quantity.



Guided Practice

A Chunk this activity into smaller, more manageable parts by first writing the equations and then comparing the constants of proportionality.

Key Takeaway:

Say, "Graphs and equations can be helpful when comparing proportional relationships."



Guided Practice

3. A red turtle moves 4 feet in 6 seconds. Its speed is $\frac{2}{3}$ ft/sec. Equation: $y = \frac{2}{3}x$
 A blue turtle moves 3 feet in 5 seconds. Its speed is $\frac{3}{5}$ ft/sec. Equation: $y = \frac{3}{5}x$
 Which turtle moves slower? How do you know?

The blue turtle. Its line is less steep.

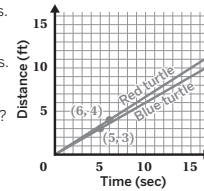

4. A red turtle moves according to the equation $y = 2x$, where y represents the distance in feet and x represents the time in seconds.

Here is a graph that shows the distance a blue turtle moves over time.

Which turtle moves faster? How do you know?

The blue turtle. The blue turtle's constant of proportionality (2.25) is greater than the red turtle's 2.

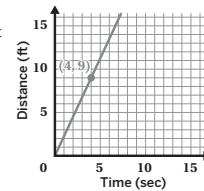

Check

Here is a graph that shows the distance three turtles move over time.

1. Which turtle moves the fastest? How do you know?

The red turtle. Its line is the steepest.

2. Write an equation for the turtle represented by the green line.

$y = \frac{7}{8}x$

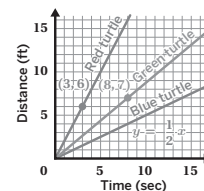

Reflection

Ask:

- "How well did you understand the math in this lesson?"
- "What questions do you still have?"



Check: Recommended Next Steps

Almost there

If students need more support, consider reviewing the definition of constant of proportionality and its relationship to the steepness of a line on a graph.

Got it!

If students need more practice, add the coordinate (1,3) to the graph in Problem 3 to represent a green turtle. Ask students to find the speed of the green turtle and write an equation. Then compare the speeds of all three turtles and determine which turtle moves slowest.

Representing Proportional Relationships

ML 2.11



Modeled Review



Name: Priya

Here are four representations of a proportional relationship. Circle or show anywhere you can see the constant of proportionality.

A baker uses 2 tablespoons of honey for every 6 cups of flour to make bread.

$$k = \frac{y}{x} \quad k = \frac{6}{2}$$

$f = 3(h)$

honey (tbsp), <i>h</i>	flour (cups), <i>f</i>
0	0
1	3
2	6

The honey represents the x-values and the flour represents the y-values.

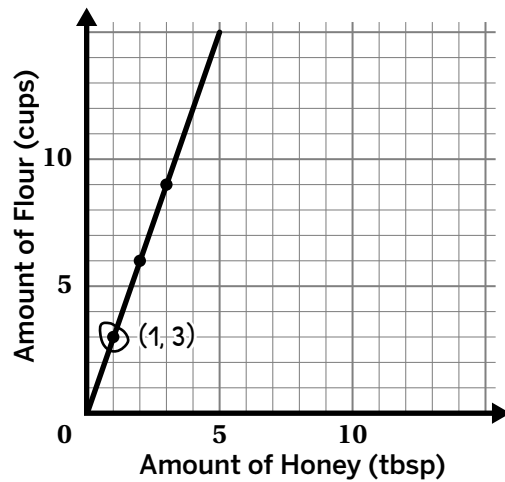

Guided Practice



- Analyze the graph and description of a proportional relationship to identify the constant of proportionality for each relationship.

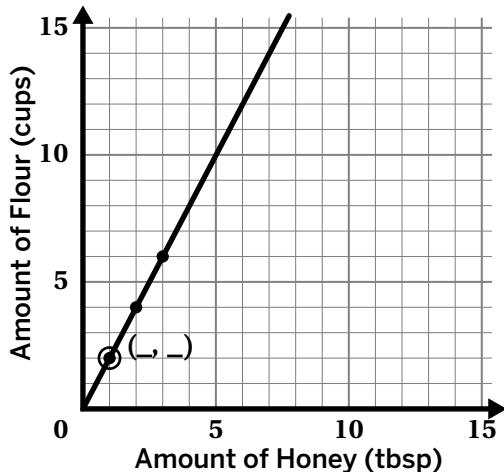

A bakery uses 1 tablespoon of honey for every 2 cups of flour to make scones.

$$k = \frac{2}{\square}$$

$$k =$$



Guided Practice



2. Here are four representations of a proportional relationship. Circle or show where you can see the constant of proportionality in each representation.

A baker uses 3 tablespoons of salt for every 15 cups of flour to make pancakes.

$f = 5s$

salt (tbsp), s	flour (cups), f
0	0
1	5
2	10
3	15

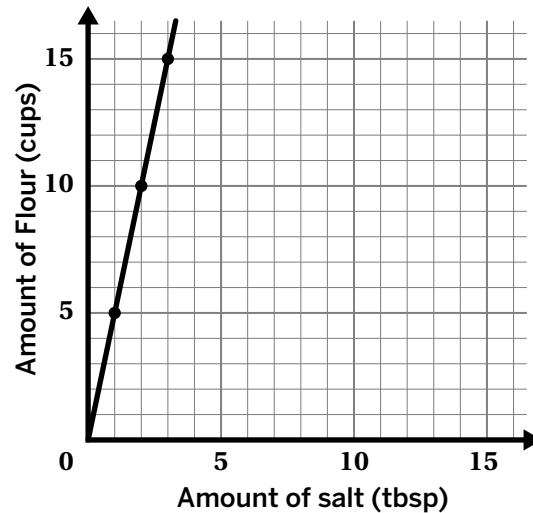

Check



- Here are four representations of a proportional relationship. Circle or show anywhere you can see the constant of proportionality.

A baker uses 3 tablespoons of sugar for every 12 cups of flour to make muffins.

$f = 4s$

sugar (tbsp), s	flour (cups), f
0	0
1	4
2	8
3	12

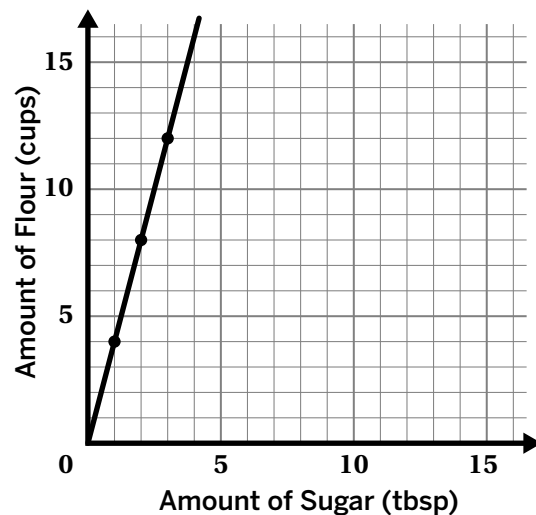

Goal

Use constants of proportionality (as determined using points or equations) or graphs to compare proportional relationships.

Standard

MA.7.AR.4.4

Materials

graph paper (optional)



Modeled Review

Point to Priya's work and **ask**:

- "How did Priya determine the constant of proportionality in the table and graph?"
- "How does Priya know to divide the amount of flour by the amount of honey?"

Reinforce Priya's thinking by saying, "Proportional relationships represent the rate at which one quantity changes in relation to another. You can find the constant of proportionality by using your knowledge of multiplication to find patterns in tables and graphs."



Guided Practice

Focus students' attention on determining the constant of proportionality.

To scaffold student thinking, **ask**:

- "How can you determine that the graph is proportional?"
- "Is it necessary for the graph to pass through the origin? Why or why not?"
- "How can you use the graph to help you calculate the constant of proportionality for the description?"

Name _____

Representing Proportional Relationships

ML 2.11

Modeled Review

Name: Priya

Here are four representations of a proportional relationship. Circle or show anywhere you can see the constant of proportionality.

A baker uses 2 tablespoons of honey for every 6 cups of flour to make bread.

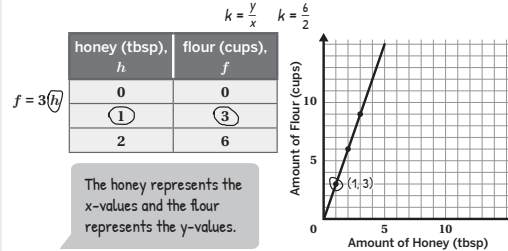

Guided Practice

1. Analyze the graph and description of a proportional relationship to identify the constant of proportionality for each relationship. **Sample work shown.**

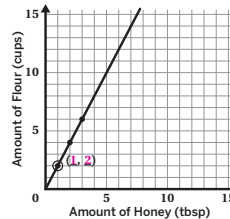

A bakery uses 1 tablespoon of honey for every 2 cups of flour to make scones.

$k = \frac{2}{1}$

$k = \frac{2}{1}$ (or equivalent)

27

© Amplify Education, Inc. and its licensors.

Vocabulary

If needed, share the meaning of the term with students.

proportional relationship: A proportional relationship is a set of equivalent ratios. The values for one quantity are each multiplied by the same number to get the values for the other quantity.



Guided Practice

A Chunk this task into smaller, more manageable parts by reviewing the graph with students before they move on to identifying the constant of proportionality in the other representations.

ML/EL Model and annotate how to determine the constant of proportionality in both the graph and the table, and then connect those representations to the equation and description.

Key Takeaway:

Say, “A proportional relationship and its constant of proportionality can be identified in a variety of representations (verbal description, table, graph, and equation).”



Guided Practice

2. Here are four representations of a proportional relationship. Circle or show where you can see the constant of proportionality in each representation.
Sample work shown.
 A baker uses 3 tablespoons of salt for every 15 cups of flour to make pancakes.

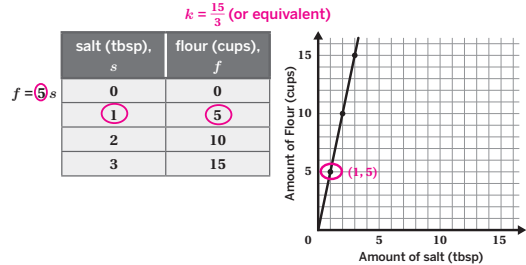

Check

Here are four representations of a proportional relationship. Circle or show anywhere you can see the constant of proportionality.
 A baker uses 3 tablespoons of sugar for every 12 cups of flour to make muffins.

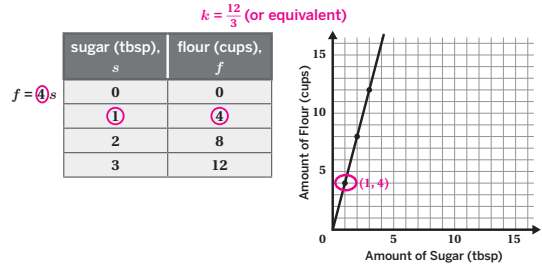

Reflection

Ask:

- “How could you determine if a relationship is proportional?”
- “Are there any representations that are still confusing?”



Check: Recommended Next Steps

Almost there

If students need more support, model annotating the units in the descriptions as y and x and then calculate the constant of proportionality.

Got it!

If students need more practice, have them determine the constant of proportionality and write an equation that matches the following descriptions:

- A baker uses 6 tablespoons of yogurt for every 4 cups of flour to make a pie crust.
- A baker uses 2 tablespoons of baking soda for every 12 cups of flour to make danishes.

Unit 3

Mini-Lessons

Determining the Circumference of a Circle

ML 3.03



Modeled Review



Name: Shawn

What is the approximate circumference of this circle? Show your thinking.

$$C = 2\pi r$$

$$C = 2\pi 10$$

$$C = 20\pi$$

Circumference: 20π inches

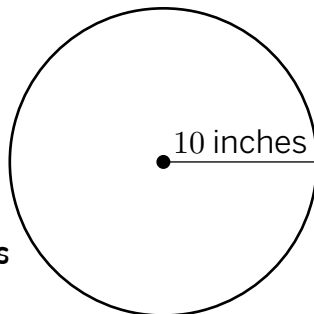

The radius is given because it is the distance from the center to the edge.



Guided Practice



Determine the circumference using $C = 2\pi r$ or $C = \pi d$. Show your thinking.

1. $C = 2\pi r$ radius = 2

$$C = 2\pi \underline{\hspace{2cm}}$$

$$C = \underline{\hspace{2cm}}$$

$$C = \underline{\hspace{3cm}} \text{ inches}$$

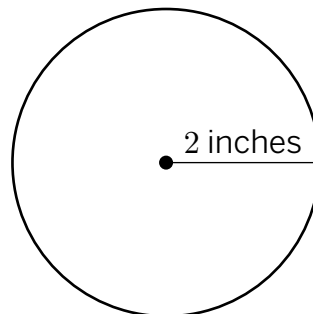

2. $C = \pi d$ diameter = $\underline{\hspace{2cm}}$

$$C = \underline{\hspace{2cm}}$$

$$C = \underline{\hspace{3cm}} \text{ inches}$$

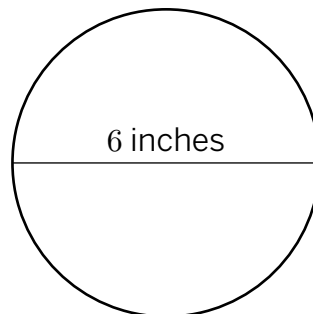



Guided Practice



3. Use the given information to determine the circumference of each object.

Object	Radius (cm)	Diameter (cm)	Circumference (cm)
Magnifying glass	5	10	
Lid	4		
Salad Plate		14	
Hand Mirror	6		
Clock		18	



Check



What is the approximate circumference of this circle?

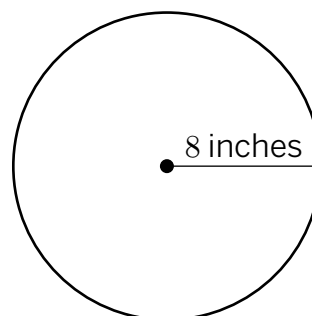

Goal

Calculate the circumference of a circle given the radius or diameter.

Standard

MA.7.GR.1.3

Materials

highlighter (optional)



Modeled Review

Point to Shawn's work and ask:

- "How did Shawn know if the problem was giving the radius or diameter?"
- "Why did Shawn use $C = 2\pi r$ to determine the circumference?"
- "What are all the ways we can represent or approximate pi?"

Reinforce the goal by saying, "The formula $C = 2\pi r$ can be used to calculate the circumference when given the radius. The formula $C = \pi d$ can be used to calculate the circumference of a circle when given the diameter."



Guided Practice

Focus students' attention on using the correct formula based on the information provided.

To scaffold their thinking, **ask**:

- "Are you given the radius or diameter?"
- "Which formula should be used?"

Name _____

Determining the Circumference of a Circle

ML 3.03

Modeled Review



Name: Shawn

What is the approximate circumference of this circle? Show your thinking.

$$C = 2\pi r$$

$$C = 2\pi 10$$

$$C = 20\pi$$

Circumference: 20π inches

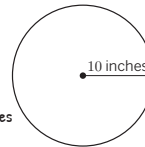

The radius is given because it is the distance from the center to the edge.



Guided Practice



Determine the circumference using $C = 2\pi r$ or $C = \pi d$. Show your thinking.

All possible responses shown.

1. $C = 2\pi r$ radius = 2

$$C = 2\pi \underline{2}$$

$$C = \underline{4\pi}$$

$$C = \underline{4\pi \text{ or } 12.56 \text{ or } \frac{88}{7}} \text{ inches}$$

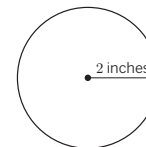

2. $C = \pi d$ diameter = 6

$$C = \underline{6\pi}$$

$$C = \underline{6\pi \text{ or } 18.84 \text{ or } \frac{13}{27}} \text{ inches}$$

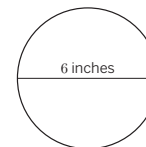

33

© Amplify Education, Inc and its licensors

Vocabulary

If needed, share the meaning of the terms with students.

circumference: The distance around a circle. (If you imagine the border of the circle as a piece of string, the circumference is the length of the string.)

diameter: The distance from one point on a circle through the center to another point on the circle. It is also the longest distance across the circle.

radius: A line segment that goes from the center to the edge of a circle.



Guided Practice

A Create an anchor chart that describes the radius, diameter, and circumference of a circle for reference.

ML/EL Provide sentence frames to help students explain their reasoning. For example, “_____ is given so I will use the _____ formula.”

Key Takeaway:

Say, “The circumference of a circle is equal to the length of the diameter, or twice the length of the radius, multiplied by π .”



Guided Practice

3. Use the given information to determine the circumference of each object.
All possible responses shown.

Object	Radius (cm)	Diameter (cm)	Circumference (cm)
Magnifying glass	5	10	10π , 31.4, or $\frac{220}{7}$
Lid	4	8	8π , 25.12, or $\frac{176}{7}$
Salad Plate	7	14	14π , 43.96, or 44
Hand Mirror	6	12	12π , 37.68, or $\frac{264}{7}$
Clock	9	18	18π , 56.52, or $\frac{396}{7}$



Check

What is the approximate circumference of this circle?
All possible responses shown.

- 16π inches
- 50.24 inches
- $\frac{352}{7}$ inches

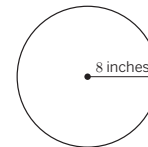

Reflection

Ask:

- “How is it helpful to know the difference between radius and diameter when calculating the circumference?”
- “How was the lesson helpful to you today?”



Check: Recommended Next Steps

Almost there

If students need more support, ask them to highlight the given radius or diameter to help them determine which equation to use. Then have them highlight the letter r or d in the formula that is needed to calculate the circumference for the circle given.

Got it!

If students need more practice, sketch the circle and ask them to determine the approximate circumference.

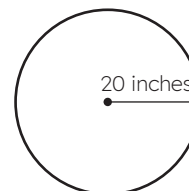

Determining the Area of a Circle

ML 3.06



Modeled Review

Name: Nick

Find the exact area of this circle.

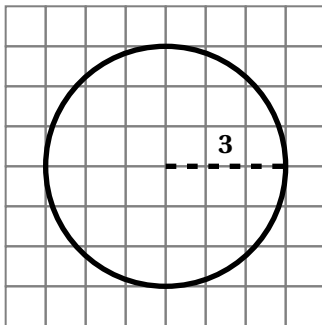

First, I drew the radius and labeled it 3 units. Then, I used the formula to calculate the area of the circle.

$$A = \pi \cdot r^2$$

$$A = \pi \cdot (3)^2$$

$$A = 9\pi$$

The area of the circle is 9π square units.



Guided Practice



- Use the radius square to estimate the area of this circle. Show or explain your thinking.

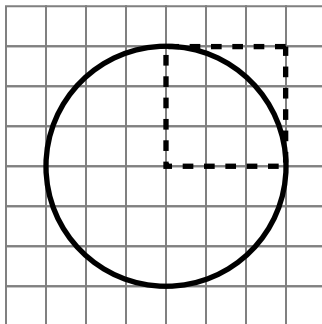



Guided Practice



2. Draw the radius for the circle and find its exact area.

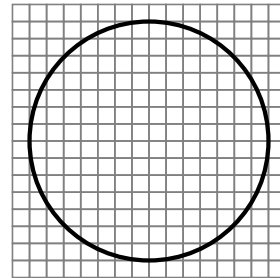

3. Find the exact and approximate area of a circle with a diameter of 10 inches. (Use 3.14 for π .) Show your thinking. (A blank circle is provided to help with your thinking.)

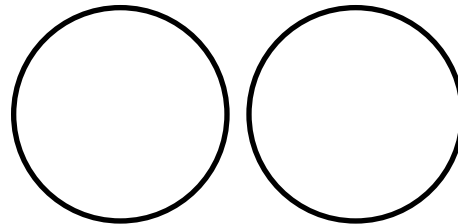

4. Jenny is making 4 circular pizzas for her family. Each pizza will have a diameter of 12 inches. Approximately how much pizza dough will she need to buy? (Use 3.14 for π .) Show your thinking.



Check



Melanie is designing circular mirrors with a diameter of 20 inches. If she is making 3 mirrors, how much glass will she need? (Use 3.14 for π .)

Goal

Apply a formula to find the area of a circle in problems of both mathematical and real word context.

Standard

MA.7.GR.1.4

Materials

Grid paper, scissors, colored pencils (optional)



Modeled Review

Point to Nick's work and **ask**:

- "How did Nick know where to draw the radius?"
- "What does *exact form* mean?"
- "Why is 3^2 equal to 9?"

Reinforce the goal by stating "If we know the radius of a circle, we can use the formula Area equals pi times the square of the radius to calculate its area."



Guided Practice

Focus students' attention on how radius squares can be used to estimate the area of a circle.

To scaffold their thinking, **ask/say**:

- "What is the area of the radius square?"
- "Approximately how many of those squares can fit inside the circle?"
- "How does the area of the 3 squares relate to the area of the circle?"

Name _____

Determining the Area of a Circle

ML 3.06



Modeled Review



Name: Nick

Find the exact area of this circle.

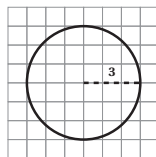

First, I drew the radius and labeled it 3 units. Then, I used the formula to calculate the area of the circle.

$$A = \pi \cdot r^2$$

$$A = \pi \cdot (3)^2$$

$$A = 9\pi$$

The area of the circle is 9π square units.



Guided Practice



1. Use the radius square to estimate the area of this circle. Show or explain your thinking.

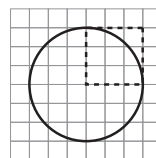

Answers vary. The area of the radius squared is $2 \cdot 2 = 4$. There are a little more than 3 radius squares in a circle. $4 \cdot 3 = 12$, so the area of the circle would be a little more than 12.

Vocabulary

If needed, share the meaning of the terms with students.

diameter of a circle: the length from one side of the circle to the opposite side, passing through the center of the circle.

radius of a circle: the length from the center of a circle to any point on the circle.

radius square: a square with a side length is the same as the radius of a given circle.



Guided Practice

A Provide students with grid paper, scissors, and highlighters to estimate the area of circles using radius squares. Help them to connect these approximations with the exact area found using the area of a circle formula.

Key Takeaway:

Say, “We can find the exact area of a circle by multiplying the square of the radius by pi. Because the value of pi is a little more than 3, we can replace pi with 3.14 and approximate the area, when solving problems in real world contexts.”



Guided Practice

2. Draw the radius for the circle and find its exact area.

49π units². Responses vary.

$$A = \pi \cdot r^2$$

$$A = \pi \cdot (7)^2$$

$$A = 49\pi$$

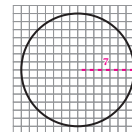

3. Find the exact and approximate area of a circle with a diameter of 10 inches. (Use 3.14 for π.) Show your thinking. (A blank circle is provided to help with your thinking.)

25π or 78.5 inches². Explanations vary.

Since the diameter of the circle is 10 inches, the radius is 5 inches.

$$A = \pi \cdot r^2$$

$$A = \pi \cdot (5)^2$$

$$A = 25\pi$$

$$A = 25(3.14) = 78.5$$



4. Jenny is making 4 circular pizzas for her family. Each pizza will have a diameter of 12 inches. Approximately how much pizza dough will she need to buy? (Use 3.14 for π.) Show your thinking.

About 452 square inches. Explanations vary. Since the diameter of each pizza is 12 inches, the radius is 6 inches.

$$A = \pi \cdot r^2$$

$$A = \pi \cdot (6)^2$$

$$A = 36\pi$$

There are 4 pizzas, so $4 \cdot 36\pi = 144\pi$

$$144(3.14) = 452.16$$



Check

Melanie is designing circular mirrors with a diameter of 20 inches. If she is making 3 mirrors, how much glass will she need? (Use 3.14 for π.)

About 942 square inches. Explanations vary. Since the diameter of one mirror is 20 inches, the radius is 10 inches.

$$A = \pi \cdot r^2$$

$$A = \pi \cdot (10)^2$$

$$A = 100\pi$$

There are 3 mirrors, so $3 \cdot 100\pi = 300\pi$

$$300(3.14) = 942$$

Reflection

Ask:

- “What is the relationship between the value of pi and the number of radius squares that fit inside a circle?”
- “How does what you learned today connect to your prior learning?”



Check: Recommended Next Steps

Almost there

If students need more support with differentiating between the diameter and the radius of a circle, have them make their own visual model with a diameter drawn. Then, have them identify and label the two radii that make up the diameter, as well as sketch more radii of the same circle.

Got it!

If students need more practice, have them revisit Problem 4 and calculate the amount of pizza dough needed to make 6 circular pizzas with a diameter of 14 inches.

Unit 4

Mini-Lessons

Calculating Percentages

ML 4.03



Modeled Review



Name: Dylan

What percentage of the larger grid is white? Explain your thinking.

I counted 25 squares. Each square has a value of 4% because 100 divided by 25 is 4. There are 10 white squares. I can multiply 4 by 10 to get 40%.

$$\frac{100}{25} = 4\%$$

$$4 \cdot 10 = 40$$

$$40\%$$

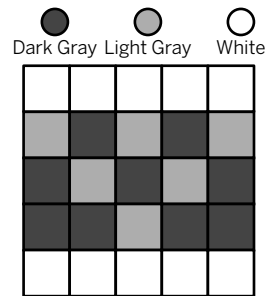

Guided Practice



1. What percentage of the grid is light gray or white? Show your thinking.

Light Gray:

$$\frac{100}{20} = \underline{\hspace{2cm}}$$

White:

Color	Percentage
Dark Gray	10%
Light Gray	
White	

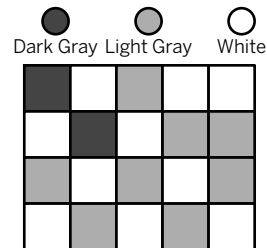



Guided Practice



Determine the percentages of the grids that are shaded each color.

2. What percentage of the grid is dark gray? Show your thinking.

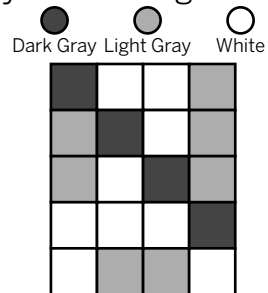

3. What percentage of the grid is white? Show your thinking.

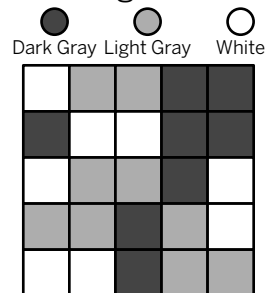

4. What percentage of the grid is light gray? Show your thinking.

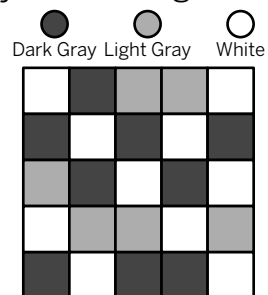

Check



What percentage of the grid is white? Show your thinking.

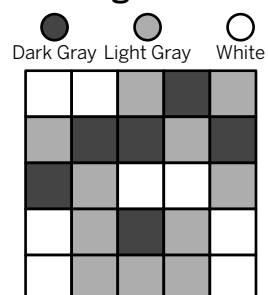

Goal

Calculate the percentage of a quantity on a grid.

Standard

MA.7.AR.3.1



Modeled Review

Point to Dylan’s work and **ask**:

- “What percentage represents 1 whole?”
- “How did Dylan use the grid to calculate the percentage of the white squares?”

Reinforce Dylan’s thinking by saying, “Finding the percentage each square represents can help you determine the total percentage of each color.”

ML/EL Provide sentence frames to support students as they explain how they determined the percentage shaded for each colored section. For example, “I counted _____ sections in the larger square.” or “There are _____ dark gray/light gray/white sections, so I _____.”



Guided Practice

Focus students’ attention on calculating the percentage of each color in the grid.

To scaffold their thinking, **ask**:

- “How many sections is the grid broken into?”
- “How many sections are there of each color?”
- “How do you calculate the percentage of each color?”

Name _____

ML 4.03

Calculating Percentages

Modeled Review

Name: Dylan

What percentage of the larger grid is white? Explain your thinking.

I counted 25 squares. Each square has a value of 4% because 100 divided by 25 is 4. There are 10 white squares. I can multiply 4 by 10 to get 40%.

$$\frac{100}{25} = 4\%$$

$$4 \cdot 10 = 40$$

$$40\%$$

Dark Gray Light Gray White

Guided Practice

1. What percentage of the grid is light gray or white? Show your thinking.

Sample work shown.

Light Gray:

$$\frac{100}{20} = 5\%$$

$$5 \cdot 8 = 40$$

Color	Percentage
Dark Gray	10%
Light Gray	40%
White	50%

Dark Gray Light Gray White

White:

$$\frac{100}{20} = 5\%$$

$$5 \cdot 10 = 50$$

43

© Amplify Education, Inc and its licensors



Guided Practice

A Chunk this task into smaller, more manageable parts by having students create a table that can be used to organize their data, including how many sections the grid is broken into and how many sections there are of each color.

Note: Students can check if they accurately determined the percentage for each color by ensuring all of the percentages add to 100%.

Key Takeaway:

Say, “Several strategies can be used to calculate the percent of a number such as multiplying the percentage by the whole, using benchmark fractions, or using a visual representation.”



Guided Practice

Determine the percentages of the grids that are shaded each color.

Sample work shown.

2. What percentage of the grid is dark gray? Show your thinking.

$$\frac{100}{20} = 5\%$$

$$5 \cdot 4 = 20$$

$$20\%$$

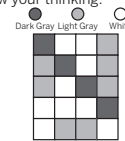

3. What percentage of the grid is white? Show your thinking.

$$\frac{100}{25} = 4\%$$

$$4 \cdot 8 = 32$$

$$32\%$$

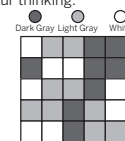

4. What percentage of the grid is light gray? Show your thinking.

$$\frac{100}{25} = 4\%$$

$$4 \cdot 6 = 24$$

$$24\%$$

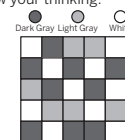

Check

What percentage of the grid is white? Show your thinking.

Sample work shown.

$$\frac{100}{25} = 4\%$$

$$4 \cdot 8 = 32$$

$$32\%$$

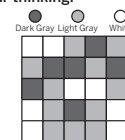

Reflection

Ask:

- “How is using a grid helpful in visualizing benchmark percentages?”
- “What questions do you still have?”



Check: Recommended Next Steps

Almost there

If students need more support, consider using Grade 6 Mini-Lesson 3.12: *Calculating Unknown Percentages*.

Got it!

If students need more practice, ask them to look at Problem 2 and determine the percentage of the remaining colors in the grid.

Finding Sales Tax and Tip

ML 4.06



Modeled Review

Name: Eva

Determine the missing values for the receipt.

Clare's meal costs \$30.00 before tax.

There is a 7% sales tax.

What is the total after tax?

$$7\% \text{ is } \frac{7}{100} \text{ or } 0.07.$$

$$30 \cdot 0.07 = 2.10$$

$$30 + 2.10 = 32.10$$

Original Cost	\$30.00
7% Tax:	\$2.10
Total:	\$32.10



Guided Practice



Determine the missing values for these receipts.

1.

Smoothie:	\$5.00
10% Tax:	\$
Total:	\$

$$5.00 \cdot 0.10 = \underline{\hspace{2cm}}$$

$$5.00 + \underline{\hspace{2cm}} = \underline{\hspace{2cm}}$$

2.

Meal:	\$20.00
20% Tip:	\$
Total:	\$

$$20.00 \cdot 0.20 = \underline{\hspace{2cm}}$$

$$20.00 + \underline{\hspace{2cm}} = \underline{\hspace{2cm}}$$



Guided Practice



Determine the missing values for these receipts.

3. Han's meal costs \$20.00 before tax.
There is a 7% sales tax.
What is the total after tax?

Original Cost	\$20.00
7% Tax:	\$
Total:	\$

4. Tristan's meal costs \$30.00 before tip.
Tristan tips 20%.
What is the total after tip?

Original Cost	\$30.00
20% Tip:	\$
Total:	\$

5. Diego's meal cost \$50.00 before tax.
There is a 5% sales tax.
What is the total after tax?

Original Cost	\$50.00
5% Tax:	\$
Total:	\$



Check



Determine the missing values for the receipt.

- Priya's meal costs \$40.00 before tax.
There is an 8% sales tax.
What is the total after tax?

Original Cost	\$40.00
8% Tax:	\$
Total:	\$

Goal

Calculate the sales tax or tip percentage to determine the new total.

Standard

MA.7.AR.3.1



Modeled Review

Point to Eva's work and **ask**:

- "Why does Eva change the percentages to decimals?"
- "How does Eva use the given sales tax to calculate the total?"

Reinforce Eva's thinking by saying, "Convert the given sales tax or tip to a decimal to calculate the total."

ML/EL Provide sentence frames to support students as they explain their strategies for converting percentages to decimals. For example, "First, I _____ because _____." or "I divided _____ by 100 because _____."



Guided Practice

Focus students' attention on using the sales tax or tip to calculate the total.

To scaffold their thinking, **ask**:

- "How do you convert the given sales tax or tip to a decimal?"
- "How do you determine the total?"

Name _____

Finding Sales Tax and Tip

ML 4.06

Modeled Review

⋮

Name: Eva

Determine the missing values for the receipt.

Clare's meal costs \$30.00 before tax.
There is a 7% sales tax.
What is the total after tax?

Original Cost	\$30.00
7% Tax:	\$2.10
Total:	\$32.10

$7\% \text{ is } \frac{7}{100} \text{ or } 0.07.$

$30 \cdot 0.07 = 2.10$
 $30 + 2.10 = 32.10$

Guided Practice

⋮

Determine the missing values for these receipts.

1. Smoothie: \$5.00
10% Tax: **\$0.50**
Total: **\$5.50**

$5.00 \cdot 0.10 = \underline{0.50}$

$5.00 + \underline{0.50} = \underline{5.50}$

2. Meal: \$20.00
20% Tip: **\$4.00**
Total: **\$24.00**

$20.00 \cdot 0.20 = \underline{4.00}$

$20.00 + \underline{4.00} = \underline{24.00}$



Guided Practice

A Chunk this task into smaller, more manageable parts by having students first convert the percentages into decimals then determine the missing values for the receipts.

Key Takeaway:

Say, “To calculate sales tax or tip, change the percentage to a decimal, multiply by the cost, and add the result to the original cost.”



Guided Practice

Determine the missing values for these receipts.

3. Han's meal costs \$20.00 before tax.

There is a 7% sales tax.

What is the total after tax?

\$21.40

Original Cost	\$20.00
7% Tax:	\$1.40
Total:	\$21.40

4. Tristan's meal costs \$30.00 before tip.

Tristan tips 20%.

What is the total after tip?

\$36.00

Original Cost	\$30.00
20% Tip:	\$6.00
Total:	\$36.00

5. Diego's meal cost \$50.00 before tax.

There is a 5% sales tax.

What is the total after tax?

\$52.50

Original Cost	\$50.00
5% Tax:	\$2.50
Total:	\$52.50



Check

Determine the missing values for the receipt.

Priya's meal costs \$40.00 before tax.

There is an 8% sales tax.

What is the total after tax?

\$43.20

Original Cost	\$40.00
8% Tax:	\$3.20
Total:	\$43.20

Reflection

Ask:

- “Why is it helpful to convert percentages to decimals when calculating the total amount including sales tax or tip?”
- “What is something you weren't sure about at the start of the lesson but understand now?”



Check: Recommended Next Steps

Almost there

If students need more support, model converting percentages to decimals. When multiplying numbers, they may need to be reminded that they don't have to line up the decimals (like in addition).

Got it!

If students need more practice, have them look at Problem 3 and ask how the total would change if the sales tax was 8%.

Applying Fractions in Proportional Relationships

ML 4.10



Modeled Review



Name: Maya

Aba and Esteban each make peach cobbler. Whose peach cobbler has more peaches per serving? Show your thinking.

Aba	Esteban
To make 6 servings, use $\frac{3}{4}$ cups of peaches	To make 4 servings, use $\frac{1}{3}$ cups of peaches

Aba	Esteban
$\frac{3}{4} \div 6 = \frac{1}{8}$ <p>$\frac{1}{8}$ peaches per serving</p>	$\frac{1}{3} \div 4 = \frac{1}{12}$ <p>$\frac{1}{12}$ peaches per serving</p>

$\frac{1}{8}$ is greater than $\frac{1}{12}$ so Aba's recipe has more peaches per serving.

Aba's recipe has more peaches per serving.



Guided Practice



- Han is making Recipe A for his family. The recipe makes 2 servings but he only wants to make 1 serving. Determine how much of each ingredient he needs for 1 serving. Show your thinking.

Strawberries: $3 \div 2 =$ _____

Sugar: $\frac{1}{2} \div$ _____ = _____

Flour: _____

Recipe A Number of servings: 2	Adjusted Recipe A Number of servings: 1
3 cups of strawberries	_____ cup of strawberries
$\frac{1}{2}$ cup of sugar	_____ cup of flour
$\frac{1}{4}$ cup of flour	_____ cup of flour



Guided Practice



Use the constant of proportionality to compare two proportional relationships. Show your thinking.

2. Diego and Dylan each make blackberry cobbler. Whose cobbler has more blackberries per serving?

Diego	Dylan
To make 6 servings, use 2 cups of blackberries	To make 4 servings, use $\frac{1}{2}$ cups of blackberries

3. Santiago and Tristan each make peach cobbler. Whose cobbler has more peaches per serving?

Santiago	Tristan
To make 2 servings, use $\frac{1}{4}$ cups of peaches	To make 3 servings, use $\frac{3}{4}$ cups of peaches



Check



Eva and Maya each make raspberry cobbler. Whose cobbler has more raspberries per serving? Show your thinking.

Eva	Maya
To make 3 servings, use $\frac{3}{4}$ cups of raspberries	To make 5 servings, use $\frac{1}{3}$ cups of raspberries

Goal

Calculate the constant of proportionality with fractional amounts.

Standard

MA.7.AR.4.2

Materials

double number lines (optional), tape diagrams (optional)



Modeled Review

Point to Maya's work and **ask**:

- "How did Maya calculate the constant of proportionality for both recipes?"
- "Where is the constant of proportionality shown in Maya's work?"
- "Why does Maya say that Aba has more peaches per serving?"

Reinforce Maya's thinking by saying, "Calculating the constant of proportionality can help compare fractional quantities."



Guided Practice

Focus students' attention on calculating the constant of proportionality.

To scaffold their thinking, **ask**:

- "How can you calculate the constant of proportionality?"
- "How do you use the constant of proportionality to compare the quantities?"
- "How can you tell which fraction is greater?"

Name _____

Applying Fractions in Proportional Relationships

ML 4.10

Modeled Review

Name: Maya

Aba and Esteban each make peach cobbler. Whose peach cobbler has more peaches per serving? Show your thinking.

Aba	Esteban
To make 6 servings, use $\frac{3}{4}$ cups of peaches	To make 4 servings, use $\frac{1}{3}$ cups of peaches

Aba	Esteban
$\frac{3}{4} \div 6 = \frac{1}{8}$	$\frac{1}{3} \div 4 = \frac{1}{12}$
$\frac{1}{8}$ peaches per serving	$\frac{1}{12}$ peaches per serving

$\frac{1}{8}$ is greater than $\frac{1}{12}$ so Aba's recipe has more peaches per serving.

Aba's recipe has more peaches per serving.



Guided Practice

- Han is making Recipe A for his family. The recipe makes 2 servings but he only wants to make 1 serving. Determine how much of each ingredient he needs for 1 serving. Show your thinking.

Strawberries: $3 \div 2 = 1\frac{1}{2}$

Sugar: $\frac{1}{2} \div 2 = \frac{1}{4}$

Flour: $\frac{1}{4} \div 2 = \frac{1}{8}$

Recipe A Number of servings: 2	Adjusted Recipe A Number of servings: 1
3 cups of strawberries	$1\frac{1}{2}$ cup of strawberries
$\frac{1}{2}$ cup of sugar	$\frac{1}{4}$ cup of flour
$\frac{1}{4}$ cup of flour	$\frac{1}{8}$ cup of flour

Vocabulary

If needed, share the meaning of the term with students.

constant of proportionality: In a proportional relationship, the number used to multiply the values for one quantity to get the values for the other quantity is called the constant of proportionality.



Guided Practice

A Invite students to draw tape diagrams, number line diagrams, or tables to help them visualize and reason about the fractional quantities. Provide a double number line or tape diagram as needed.

ML/EL Provide sentence frames to support students as they share their comparisons. For example, “___’s recipe has more ___ per serving.”

Key Takeaway:

Say, “Calculating the constants of proportionality can help compare proportional relationships involving fractional quantities.”



Guided Practice

Use the constant of proportionality to compare two proportional relationships. Show your thinking. **Sample work shown.**

2. Diego and Dylan each make blackberry cobbler. Whose cobbler has more blackberries per serving?

Diego	Dylan
To make 6 servings, use 2 cups of blackberries	To make 4 servings, use $\frac{1}{2}$ cups of blackberries

Diego	Dylan	Diego's recipe has more blackberries per serving.
$2 \div 6 = \frac{1}{3}$	$\frac{1}{2} \div 4 = \frac{1}{8}$	

3. Santiago and Tristan each make peach cobbler. Whose cobbler has more peaches per serving?

Santiago	Tristan
To make 2 servings, use $\frac{1}{4}$ cups of peaches	To make 3 servings, use $\frac{3}{4}$ cups of peaches

Santiago	Tristan	Tristan's recipe has more peaches per serving.
$\frac{1}{4} \div 2 = \frac{1}{8}$	$\frac{3}{4} \div 3 = \frac{1}{4}$	



Check

Eva and Maya each make raspberry cobbler. Whose cobbler has more raspberries per serving? Show your thinking. **Sample work shown.**

Eva	Maya
To make 3 servings, use $\frac{3}{4}$ cups of raspberries	To make 5 servings, use $\frac{1}{3}$ cups of raspberries

Eva	Maya	Eva's recipe has more raspberries per serving.
$\frac{3}{4} \div 3 = \frac{1}{4}$	$\frac{1}{3} \div 5 = \frac{1}{15}$	

Reflection

Ask:

- “How does calculating the constants of proportionality help compare proportional relationships?”
- “How does what you learned today connect to your prior learning?”



Check: Recommended Next Steps

Almost there

If students need more support, consider using a double number line to help them visually compare the proportional relationships.

Got it!

If students need more practice, sketch the table and ask them to determine whose recipe has more bananas per serving.

Kai	Shawn
To make 4 servings, use:	To make 9 servings, use:
• $\frac{1}{4}$ cup of bananas	• $\frac{3}{4}$ cup of bananas

Unit 5

Mini-Lessons

Dividing Integers

ML 5.04



Modeled Review

Name: Han

Select the two expressions that have the same value.

A. $\frac{-20}{4}$
-5

B. $\frac{-20}{-4}$
5

C. $\frac{20}{-4}$
-5

When dividing integers, like signs result in a positive quotient. Unlike signs result in a negative quotient.



Guided Practice



1. Evaluate each expression. Circle *all* the expressions with a negative quotient.

A. $\frac{-6}{2}$

B. $\frac{6}{-2}$

C. $\frac{-6}{-2}$

2. Evaluate each expression. Circle *all* the expressions with a negative quotient.

A. $\frac{-12}{3}$

B. $\frac{-12}{-3}$

C. $\frac{12}{-3}$

3. Evaluate each expression. Circle *all* the expressions with a negative quotient.

A. $\frac{-15}{5}$

B. $\frac{15}{-5}$

C. $\frac{-15}{-5}$



Guided Practice



Calculate the quotients of the expressions.

4. $\frac{10}{-2}$

5. $\frac{-12}{-6}$

6. $\frac{-20}{10}$

7. $\frac{36}{-6}$

8. $\frac{-18}{-9}$

9. $\frac{-16}{4}$

10. $\frac{-24}{-6}$

11. $\frac{-9}{-3}$



Check



Select the two expressions that have the same value.

A. $\frac{30}{-5}$

B. $\frac{-30}{-5}$

C. $\frac{-30}{5}$

Goal

Divide positive and negative numbers.

Standard

MA.7.NSO.2.2

Materials

highlighter (optional), coloring tools (optional)

**Modeled Review**Point to Han's work and **ask**:

- "How did Han use the rules for dividing integers to identify the expressions that have the same quotients?"
- "What do A and C have in common? How is B different?"

Reinforce Han's thinking by saying, "When you divide integers that have the same sign, you get a positive number. When you divide integers that have different signs, you get a negative number."

**Guided Practice**

Focus students' attention on using the signs of the numbers to determine the sign of the quotient.

To scaffold their thinking, **ask**:

- "Do the integers have the same or different signs?"
- "If the signs are the same, what will be the sign of the quotient? What if the signs are different?"

Name _____

Dividing Integers

ML 5.04

Modeled Review

Name: Han

Select the two expressions that have the same value.

A. $\frac{-20}{4}$
-5

B. $\frac{-20}{-4}$
5

C. $\frac{20}{-4}$
-5

When dividing integers, like signs result in a positive quotient. Unlike signs result in a negative quotient.

Guided Practice1. Evaluate each expression. Circle *all* the expressions with a negative quotient.

A. $\frac{-6}{2}$
-3

B. $\frac{6}{-2}$
-3

C. $\frac{-6}{2}$
3

2. Evaluate each expression. Circle *all* the expressions with a negative quotient.

A. $\frac{-12}{3}$
-4

B. $\frac{-12}{-3}$
4

C. $\frac{12}{-3}$
-4

3. Evaluate each expression. Circle *all* the expressions with a negative quotient.

A. $\frac{-15}{5}$
-3

B. $\frac{15}{-5}$
-3

C. $\frac{-15}{-5}$
3

57

© Amplify Education, Inc. and its licensors.

Vocabulary

If needed, share the meaning of the term with students.

integers: Whole numbers and their opposites.



Guided Practice

A Guide visualization by suggesting students color code the positive and negative numbers.

ML/EL Support students in explaining their answers by providing them with the following sentence frames:

- “A positive number divided by a negative number always results in _____.”
- “A negative number divided by a negative number always results in _____.”

Key Takeaway:

Say, “The sign of a quotient is dependent on the signs of the numbers being divided.”



Guided Practice

Calculate the quotients of the expressions.

4. $\frac{10}{-2}$

-5

5. $\frac{-12}{6}$

2

6. $\frac{-20}{10}$

-2

7. $\frac{36}{-6}$

-6

8. $\frac{-18}{-9}$

2

9. $\frac{-16}{4}$

-4

10. $\frac{-24}{-6}$

4

11. $\frac{-9}{-3}$

3



Check

Select the two expressions that have the same value.

A. $\frac{30}{-5}$

-6

B. $\frac{-30}{-5}$

6

C. $\frac{-30}{5}$

-6

Reflection

Ask:

- “Do $\frac{-6}{3}$ and $\frac{6}{-3}$ have the same value? How do you know?”
- “How was the lesson helpful to you today?”



Check: Recommended Next Steps

Almost there

If students need more support, consider rewriting the division problem as a multiplication equation to help students understand how the signs of the divisor and dividend impact the sign of the quotient.

Got it!

If students need more practice, present them with the following expressions and ask them to circle the two that have the same value.

A. $\frac{40}{-8}$

B. $\frac{-40}{-8}$

C. $\frac{-40}{8}$

Multiplying Powers

ML 5.07



Modeled Review



Name: Jack

Decide if the expressions in each pair are equivalent. Show your thinking.

Expression 1	Expression 2	Equivalent?
$(5^5)^2$ $(5^5) \cdot (5^5)$ $(5 \cdot 5 \cdot 5 \cdot 5 \cdot 5) \cdot (5 \cdot 5 \cdot 5 \cdot 5 \cdot 5)$	$5^4 \cdot 5^3$ $(5 \cdot 5 \cdot 5 \cdot 5) \cdot (5 \cdot 5 \cdot 5)$	Yes <input checked="" type="radio"/> No
$4^3 \cdot 2^5$ $(4 \cdot 4 \cdot 4) \cdot (2 \cdot 2 \cdot 2 \cdot 2 \cdot 2)$ $(4 \cdot 2)(4 \cdot 2)(4 \cdot 2) \cdot 2 \cdot 2$	8^8 $(8 \cdot 8 \cdot 8 \cdot 8 \cdot 8 \cdot 8 \cdot 8 \cdot 8)$	Yes <input checked="" type="radio"/> No
$15^3 \cdot 2^3$ $(15 \cdot 15 \cdot 15) \cdot (2 \cdot 2 \cdot 2)$ $(15 \cdot 2)(15 \cdot 2)(15 \cdot 2)$	$(5 \cdot 2)^3 \cdot 3^3$ $(10 \cdot 10 \cdot 10) \cdot (3 \cdot 3 \cdot 3)$ $(10 \cdot 3)(10 \cdot 3)(10 \cdot 3)$	<input checked="" type="radio"/> Yes No



Guided Practice



1. Match each expression to the correct expanded form on the right.

Expression

Expanded Form

$(3^4)^2$

$3 \cdot 3 \cdot 3 \cdot 3 \cdot 3 \cdot 3 \cdot 3 \cdot 3 \cdot 3$

3^9

$(3 \cdot 3 \cdot 3) \cdot (3 \cdot 3 \cdot 3)$

$(3^3) \cdot (3^3)$

$(3 \cdot 3 \cdot 3 \cdot 3) \cdot (3 \cdot 3 \cdot 3 \cdot 3)$



Guided Practice



2. Decide if the expressions in each pair are equivalent. Show your thinking.

Expression 1	Expression 2	Equivalent?
$(7^4)^2$	49^4	Yes No
$6^3 \cdot 2^4$	$(2 \cdot 2)^3 \cdot 3^3$	Yes No
$5^3 \cdot 2^3$	10	Yes No
$(6^4)^2$	$6^4 \cdot 6^2$	Yes No
$8^4 \cdot 3^3$	$(3 \cdot 2)^4 \cdot 4^3$	Yes No



Check



Decide if the expressions in each pair are equivalent. Show your thinking.

Expression 1	Expression 2	Equivalent?
$(4^3)^2$	$4^3 \cdot 4^3$	Yes No
$3^2 \cdot 2^3$	6^5	Yes No

Goal

Multiply expressions with exponents and determine equivalence.

Standard

MA.7.NSO.1.1



Modeled Review

Point to Jack's work and **ask**:

- "How did Jack show that $(5^5)^2$ is not equivalent to $5^4 \cdot 5^3$?"
- "How is expanded form helpful in determining whether the expressions are equivalent?"
- "Why is it helpful to rearrange the factors to show $15^3 \cdot 2^3$ is equivalent to $(5 \cdot 2)^3 \cdot 3^3$?"

Reinforce Jack's thinking by saying, "Expanded form is useful in determining whether expressions with exponents are equivalent."

ML/EL Provide sentence frames to help students explain strategies for simplifying expressions with exponents. For example, "I need to simplify what's in parentheses first because ____." or "First, I need to write it in expanded form because ____."



Guided Practice

Focus students' attention on matching each expression to its equivalent expanded form.

To scaffold their thinking, **say**:

- "First, evaluate and simplify what is in parentheses."
- "Then, write each expression in expanded form and rearrange the factors if needed."

Name _____

ML 5.07

Multiplying Powers

Modeled Review

Name: Jack

Decide if the expressions in each pair are equivalent. Show your thinking.

Expression 1	Expression 2	Equivalent?
$(5^5)^2$ $(5^5) \cdot (5^5)$ $(5 \cdot 5 \cdot 5 \cdot 5 \cdot 5) \cdot (5 \cdot 5 \cdot 5 \cdot 5 \cdot 5)$	$5^4 \cdot 5^3$ $(5 \cdot 5 \cdot 5 \cdot 5) \cdot (5 \cdot 5 \cdot 5)$	Yes <input type="radio"/> No <input checked="" type="radio"/>
$4^3 \cdot 2^5$ $(4 \cdot 4 \cdot 4) \cdot (2 \cdot 2 \cdot 2 \cdot 2 \cdot 2)$ $(4 \cdot 2)(4 \cdot 2)(4 \cdot 2) \cdot 2 \cdot 2$	8^8 $(8 \cdot 8 \cdot 8 \cdot 8 \cdot 8 \cdot 8 \cdot 8 \cdot 8)$	Yes <input type="radio"/> No <input checked="" type="radio"/>
$15^3 \cdot 2^3$ $(15 \cdot 15 \cdot 15) \cdot (2 \cdot 2 \cdot 2)$ $(15 \cdot 2)(15 \cdot 2)(15 \cdot 2)$	$(5 \cdot 2)^3 \cdot 3^3$ $(10 \cdot 10 \cdot 10) \cdot (3 \cdot 3 \cdot 3)$ $(10 \cdot 3)(10 \cdot 3)(10 \cdot 3)$	Yes <input checked="" type="radio"/> No <input type="radio"/>

Guided Practice

1. Match each expression to the correct expanded form on the right.

Expression	Expanded Form
$(3^4)^2$	$3 \cdot 3 \cdot 3 \cdot 3 \cdot 3 \cdot 3 \cdot 3 \cdot 3$
3^9	$(3 \cdot 3 \cdot 3) \cdot (3 \cdot 3 \cdot 3)$
$(3^3) \cdot (3^3)$	$(3 \cdot 3 \cdot 3 \cdot 3) \cdot (3 \cdot 3 \cdot 3 \cdot 3)$

61 © Amplify Education, Inc and its licensors

 **Guided Practice**

A Chunk this task into smaller, more manageable parts by having students evaluate one expression at a time before determining if the expressions are equivalent.

Key Takeaway:

Say, “When determining if two expressions are equal, it helps to expand the exponents. You can also use the structure of the expression and rearrange the factors to see if they are equivalent.”

 **Guided Practice**

2. Decide if the expressions in each pair are equivalent. Show your thinking.
Sample work shown.

Expression 1	Expression 2	Equivalent?
$(7^9)^2$ $(7^9)(7^9)$ $(7 \cdot 7 \cdot 7 \cdot 7 \cdot 7) \cdot (7 \cdot 7 \cdot 7 \cdot 7 \cdot 7)$ $(7 \cdot 7)(7 \cdot 7)(7 \cdot 7)(7 \cdot 7)$	49^4 $49 \cdot 49 \cdot 49 \cdot 49$	Yes <input type="radio"/> No <input checked="" type="radio"/>
$6^3 \cdot 2^4$ $(6 \cdot 6 \cdot 6) \cdot (2 \cdot 2 \cdot 2 \cdot 2)$ $(6 \cdot 2)(6 \cdot 2)(6 \cdot 2) \cdot 2$	$(2 \cdot 2)^3 \cdot 3^3$ $(4 \cdot 4 \cdot 4) \cdot (3 \cdot 3 \cdot 3)$ $(4 \cdot 3)(4 \cdot 3)(4 \cdot 3)$	Yes <input checked="" type="radio"/> No <input type="radio"/>
$5^3 \cdot 2^3$ $(5 \cdot 5 \cdot 5) \cdot (2 \cdot 2 \cdot 2)$ $(5 \cdot 2)(5 \cdot 2)(5 \cdot 2)$	10 $10 \cdot 10 \cdot 10$	Yes <input checked="" type="radio"/> No <input type="radio"/>
$(6^4)^2$ $(6^4)(6^4)$ $(6 \cdot 6 \cdot 6 \cdot 6) \cdot (6 \cdot 6 \cdot 6 \cdot 6)$	$6^4 \cdot 6^2$ $(6 \cdot 6 \cdot 6 \cdot 6) \cdot (6 \cdot 6)$	Yes <input checked="" type="radio"/> No <input type="radio"/>
$8^4 \cdot 3^3$ $(8 \cdot 8 \cdot 8 \cdot 8) \cdot (3 \cdot 3 \cdot 3)$ $(8 \cdot 3)(8 \cdot 3)(8 \cdot 3) \cdot 8$	$(3 \cdot 2)^4 \cdot 4^3$ $(6 \cdot 6 \cdot 6 \cdot 6)(4 \cdot 4 \cdot 4)$ $(6 \cdot 4)(6 \cdot 4)(6 \cdot 4) \cdot 6$	Yes <input checked="" type="radio"/> No <input type="radio"/>

 **Check**

Decide if the expressions in each pair are equivalent. Show your thinking.
Sample work shown.

Expression 1	Expression 2	Equivalent?
$(4^3)^2$ $(4^3) \cdot (4^3)$ $(4 \cdot 4 \cdot 4) \cdot (4 \cdot 4 \cdot 4)$	$4^3 \cdot 4^3$ $(4 \cdot 4 \cdot 4) \cdot (4 \cdot 4 \cdot 4)$	Yes <input checked="" type="radio"/> No <input type="radio"/>
$3^2 \cdot 2^3$ $(3 \cdot 3) \cdot (2 \cdot 2 \cdot 2)$ $(3 \cdot 2)(3 \cdot 2) \cdot 2$	6^5 $6 \cdot 6 \cdot 6 \cdot 6 \cdot 6$	Yes <input checked="" type="radio"/> No <input type="radio"/>

Reflection

Ask:

- “What are some important things to remember when determining whether expressions with exponents are equivalent?”
- “What questions do you still have?”

 **Check: Recommended Next Steps**

Almost there

If students need more support, consider using visual aids, such as anchor charts, to illustrate the order of operations and guide students through the correct sequence of steps to evaluate expressions with exponents.

Got it!

If students need more practice, ask them to decide if the following expressions are equivalent or not.

Expression 1	Expression 2
$(5^3)^2$	$5^4 \cdot 5$
$8^4 \cdot 2^4$	16^4
$12^2 \cdot 2^3$	$(3 \cdot 2)^2 \cdot 4^3$

Unit 6

Mini-Lessons

Writing Equations From Descriptions and Tape Diagrams

ML 6.02



Modeled Review



Name: Priya

Ella ran 6 times around her school building. Then she ran 4 miles home. Her phone told her that she ran 7 miles total.

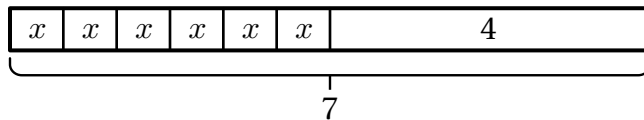

x appeared six times while 4 appeared only once. The sum is represented by 7, so the equation can be written as $6x + 4 = 7$.

Write an equation that represents this situation.

$$6x + 4 = 7$$



Guided Practice



- Match each equation to the correct tape diagram on the left and description on the right.

Tape diagram

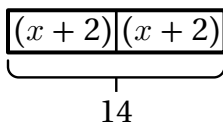

Equation

$$3x + 2 = 14$$

Description

Caleb collected 14 seashells at the beach, saving 2 for his collection and sharing the rest equally among his 3 teammates.

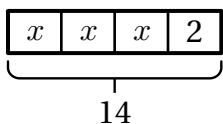

$$2(x + 2) = 14$$

Fatima gathered 14 marbles and set aside 2 for herself before splitting the remainder equally among her 4 cousins.

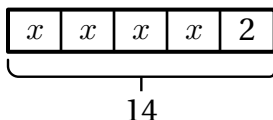

$$4x + 2 = 14$$

Felipe bought 2 books, one for each of his siblings to read. They each spent \$2 on bookmarks. The total bill was \$14.



Guided Practice



Write an equation that matches the description and tape diagram.

2. Ava ordered 3 slices of pizza, one for each friend at the sleepover. Each guest contributed \$5 for dessert. The total bill was \$21.

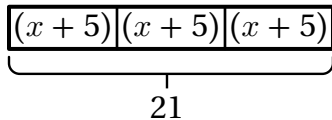

3. Mia baked 10 cupcakes and reserved 4 for herself before sharing the remaining treats equally among her 2 siblings.

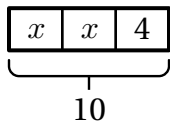

4. Maya purchased 4 tickets for a movie night, one for each family member. Afterward, each person bought a snack for \$3. The total bill was \$24.

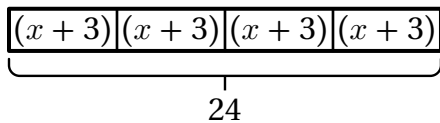

5. Emma bought 18 stickers and decided to keep 3 for her collection before distributing the remaining stickers equally among her 5 cousins.

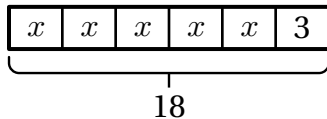

6. Alexis bought 5 servings of ice cream, one for each friend at the game. Each person chipped in \$3 for toppings. The total bill was \$40.

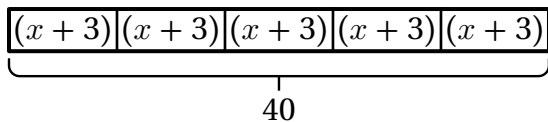

Check



Write an equation that matches the description and tape diagram.

Esteban walked 4 times around the park. Then he walked 2 miles to the school. His watch told him that he walked 8 miles total.

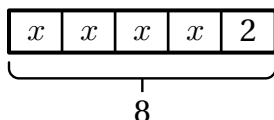

Goal

Write an equation to represent a tape diagram and a description.

Standard

MA.7.AR.2.2

Materials

highlighter (optional)



Modeled Review

Point to Priya's work and **ask**:

- "How is each part of the equation $6x + 4 = 7$ represented in the tape diagram?"
- "How did Priya know there wasn't grouping involved in the equation being represented?"
- "What are other equivalent forms of the equation?"

Reinforce Priya's thinking by saying, "Descriptions, tape diagrams, and equations can all be used to represent the same situation."



Guided Practice

Focus students' attention on identifying the tape diagram and description that match each equation.

To scaffold their thinking, **ask**:

- "Is the tape diagram divided into equal parts? If so, what are those parts?"
- "Is the tape diagram divided into a few equal sections along with one unequal part? Can you identify them?"
- "What is the total?"

Name _____

Writing Equations From Descriptions and Tape Diagrams

ML 6.02

Modeled Review

Name: Priya

Ella ran 6 times around her school building. Then she ran 4 miles home. Her phone told her that she ran 7 miles total.

x
x
x
x
x
x
x
4

7

Write an equation that represents this situation.

$6x + 4 = 7$

x appeared six times while 4 appeared only once. The sum is represented by 7, so the equation can be written as $6x + 4 = 7$.

Guided Practice

1. Match each equation to the correct tape diagram on the left and description on the right.

Tape diagram	Equation	Description
<div style="border: 1px solid gray; padding: 5px; display: flex; align-items: center; gap: 5px;"> $(x + 2)$ $(x + 2)$ </div> <p style="text-align: center; margin-top: 5px;">14</p>	<p>$3x + 2 = 14$</p>	<p>Caleb collected 14 seashells at the beach, saving 2 for his collection and sharing the rest equally among his 3 teammates.</p>
<div style="border: 1px solid gray; padding: 5px; display: flex; align-items: center; gap: 5px;"> x x x 2 </div> <p style="text-align: center; margin-top: 5px;">14</p>	<p>$2(x + 2) = 14$</p>	<p>Fatima gathered 14 marbles and set aside 2 for herself before splitting the remainder equally among her 4 cousins.</p>
<div style="border: 1px solid gray; padding: 5px; display: flex; align-items: center; gap: 5px;"> x x x x 2 </div> <p style="text-align: center; margin-top: 5px;">14</p>	<p>$4x + 2 = 14$</p>	<p>Felipe bought 2 books, one for each of his siblings to read. They each spent \$2 on bookmarks. The total bill was \$14.</p>



Guided Practice

A Display a blank template of a tape diagram labeling the different parts with generalizations for what content will go inside.

Key Takeaway:

Say, "Equations and tape diagrams can be used to represent and model situations."



Guided Practice



Write an equation that matches the description and tape diagram.

Sample responses shown.

2. Ava ordered 3 slices of pizza, one for each friend at the sleepover. Each guest contributed \$5 for dessert. The total bill was \$21.

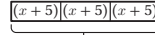

$$3(x + 5) = 21$$

3. Mia baked 10 cupcakes and reserved 4 for herself before sharing the remaining treats equally among her 2 siblings.



$$2x + 4 = 10$$

4. Maya purchased 4 tickets for a movie night, one for each family member. Afterward, each person bought a snack for \$3. The total bill was \$24.

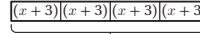

$$4(x + 3) = 24$$

5. Emma bought 18 stickers and decided to keep 3 for her collection before distributing the remaining stickers equally among her 5 cousins.

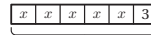

$$5x + 3 = 18$$

6. Alexis bought 5 servings of ice cream, one for each friend at the game. Each person chipped in \$3 for toppings. The total bill was \$40.

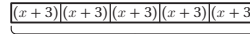

$$5(x + 3) = 40$$



Check



Write an equation that matches the description and tape diagram.

Sample response shown.

- Esteban walked 4 times around the park. Then he walked 2 miles to the school. His watch told him that he walked 8 miles total.

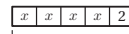

$$4x + 2 = 8$$

Reflection

Ask:

- "How is a tape diagram helpful in representing equations?"
- "Reflect on your learning today. What were you most proud of?"



Check: Recommended Next Steps

Almost there

If students need more support, consider highlighting words in the description and pairing them with the appropriate operation symbol. For example, highlight words like "each," "purchased," "keep," and "distributed" alongside their respective operations.

Got it!

If students need more practice, present them with the following tape diagram and description. Ask them to write an equation that represents both the diagram and description.

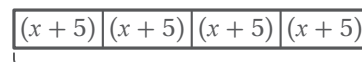

36

Sara bought 4 shirts, one for each friend. Each friend added \$5 for shipping. The total cost was \$36.

Solving Equations With Positive and Negative Numbers

ML 6.06



Modeled Review

Name: Jack

Solve the equation. Show your thinking.

$$-4(x - 2) = 12$$

$$\frac{-4}{-4}(x - 2) = \frac{12}{-4}$$

$$x - 2 = -3$$

$$x - 2 = -3$$

$$+ 2 \quad + 2$$

$$x = -1$$

Check:

$$-4(x - 2) = 12$$

$$-4(-1 - 2) = 12$$

$$-4(-3) = 12$$

$$12 = 12$$



Guided Practice



1. Solve the equations by completing the blanks in the equations and descriptions.

Equation	Moves
$-2x + 3 = 7$ $-2x = \underline{\quad}$ $x = \underline{\quad}$	<p>Step 1: Subtract <u> </u> from each side.</p> <p>Step 2: Divide each side by <u> </u>.</p>
$2(x + 1) = 6$ $x + 1 = \underline{\quad}$ $x = \underline{\quad}$	<p>Step 1: <u> </u> each side by <u> </u>.</p> <p>Step 2: <u> </u> from each side.</p>



Guided Practice



For Problems 2–5, solve the equation. Show your thinking.

2. $-4x - 2 = 10$

3. $3(x - 2) = 9$

4. $-3x + 5 = -1$

5. $-4(x + 3) = 20$



Check



Solve each equation. Show your thinking.

1. $-4x - 3 = 13$

2. $-3(x - 4) = 27$

Goal

Solve linear equations that involve positive and negative numbers.

Standard

MA.7.AR.2.2

Materials

highlighter (optional)



Modeled Review

Point to Jack's work and **ask**:

- "Why did Jack use inverse operations to solve for the variable?"
- "Why did Jack do the same operation on both sides of the equal sign?"
- "How did Jack check his solution?"

Reinforce Jack's thinking by saying, "When solving an equation, the same operations should be applied to both sides at each step, so that the equation remains true."



Invite students to check the solution by substituting in the value for the variable and evaluating to determine whether the equation is true.



Guided Practice

Focus students' attention on solving equations by ensuring that both sides of the equation remain balanced while determining the value of the variable.

To scaffold their thinking, **say**:

- "Identify the variable that needs to be solved for."
- "Apply the inverse operation to both sides of the equation, repeating this process until the variable is isolated."

Name _____

Solving Equations With Positive and Negative Numbers

ML 6.06



Modeled Review



Name: Jack

Solve the equation. Show your thinking.

$$-4(x - 2) = 12$$

$$\begin{aligned} -4(x - 2) &= 12 \\ -4 & \quad -4 \\ x - 2 &= -3 \\ +2 & \quad +2 \\ x &= -1 \end{aligned}$$

Check:

$$\begin{aligned} -4(x - 2) &= 12 \\ -4(-1 - 2) &= 12 \\ -4(-3) &= 12 \\ 12 &= 12 \end{aligned}$$



Guided Practice



1. Solve the equations by completing the blanks in the equations and descriptions.

Equation	Moves
$\begin{aligned} -2x + 3 &= 7 \\ -2x &= 4 \\ x &= -2 \end{aligned}$	<p>Step 1: Subtract <u>3</u> from each side.</p> <p>Step 2: Divide each side by <u>-2</u>.</p>
$\begin{aligned} 2(x + 1) &= 6 \\ x + 1 &= 3 \\ x &= 2 \end{aligned}$	<p>Step 1: <u>Divide</u> each side by <u>2</u>.</p> <p>Step 2: <u>Subtract 1</u> from each side.</p>



Guided Practice

A Invite students to highlight the variable in each equation. Then have them make a step by step plan as to how they will isolate the variable. (For example, first I will divide. Next, I will add and finally, I will subtract.)

Key Takeaway:

Say, “The first step in solving equations may be different depending on the structure of the equation, but it is important that both sides of the equation remain balanced.”



Guided Practice

For Problems 2–5, solve the equation. Show your thinking.

Sample work shown.

2. $-4x - 2 = 10$

$$\begin{array}{r} -4x - 2 = 10 \\ +2 \quad +2 \\ \hline -4x = 12 \\ -4 \quad -4 \\ \hline x = -3 \end{array}$$

3. $3(x - 2) = 9$

$$\begin{array}{r} 3(x - 2) = 9 \\ 3 \quad 3 \\ \hline x - 2 = 3 \\ +2 \quad +2 \\ \hline x = 5 \end{array}$$

4. $-3x + 5 = -1$

$$\begin{array}{r} -3x + 5 = -1 \\ -5 \quad -5 \\ \hline -3x = -6 \\ -3 \quad -3 \\ \hline x = 2 \end{array}$$

5. $-4(x + 3) = 20$

$$\begin{array}{r} -4(x + 3) = 20 \\ -4 \quad -4 \\ \hline x + 3 = -5 \\ -3 \quad -3 \\ \hline x = -8 \end{array}$$



Check

Solve each equation. Show your thinking. Sample work shown.

1. $-4x - 3 = 13$

$$\begin{array}{r} -4x - 3 = 13 \\ +3 \quad +3 \\ \hline -4x = 16 \\ -4 \quad -4 \\ \hline x = -4 \end{array}$$

2. $-3(x - 4) = 27$

$$\begin{array}{r} -3(x - 4) = 27 \\ -3 \quad -3 \\ \hline x - 4 = -9 \\ +4 \quad +4 \\ \hline x = -5 \end{array}$$

Reflection

Ask:

- “What suggestions would you share with a friend about solving equations that involve positive and negative numbers?”
- “Why is it helpful to check your solutions?”



Check: Recommended Next Steps

Almost there

If students need more support, invite them to draw a line separating the two sides of the equation to support them in organizing their work on each side of the equation.

Got it!

If students need more practice, ask them to solve the following equations:

- $-3(x - 5) = 21$
- $-5x + 6 = 21$

Solving Inequalities

ML 6.15



Modeled Review



Name: Priya

Solve and graph the solution to $x - 1 > 5$.

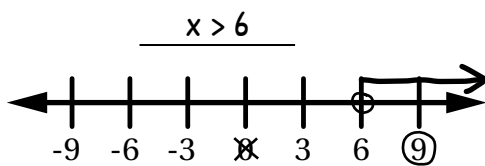

$$x - 1 = 5$$

$$\begin{array}{r} +1 \quad +1 \\ x - 1 = 5 \end{array}$$

$$x = 6$$

$$x < 6$$

$$0 - 1 > 5$$

$$-1 > 5$$

False

$$x > 6$$

$$(9) - 1 > 5$$

$$8 > 5$$

True



Guided Practice



- Graph the solution to the inequality $3x \geq 9$ by finding the boundary point and testing values on both sides of the boundary point.

Moves	Work								
Move 1: Find the boundary point.	$\frac{3x}{3} = \frac{9}{3}$ $x = \underline{\quad}$								
Move 2: Test the values on both sides of the point and determine whether the statement is true or false.	<table style="width: 100%; border: none;"> <tr> <td style="text-align: center; border: none;">Less than or equal to</td> <td style="text-align: center; border: none;">Greater than or equal to</td> </tr> <tr> <td style="text-align: center; border: none;">$3(\underline{\quad}) \geq 9$</td> <td style="text-align: center; border: none;">$3(\underline{\quad}) \geq 9$</td> </tr> <tr> <td style="text-align: center; border: none;">$\underline{\quad} \geq 9$</td> <td style="text-align: center; border: none;">$\underline{\quad} \geq 9$</td> </tr> <tr> <td style="text-align: center; border: none;">_____</td> <td style="text-align: center; border: none;">_____</td> </tr> </table>	Less than or equal to	Greater than or equal to	$3(\underline{\quad}) \geq 9$	$3(\underline{\quad}) \geq 9$	$\underline{\quad} \geq 9$	$\underline{\quad} \geq 9$	_____	_____
Less than or equal to	Greater than or equal to								
$3(\underline{\quad}) \geq 9$	$3(\underline{\quad}) \geq 9$								
$\underline{\quad} \geq 9$	$\underline{\quad} \geq 9$								
_____	_____								
Move 3: Graph the solution.									



Guided Practice



Solve and graph the solution to each of the inequalities.

2. $2x \leq -8$ _____

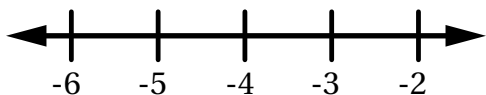

3. $x - 1 > -7$ _____

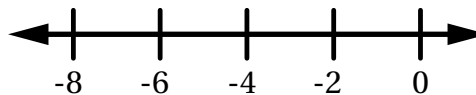

4. $x + 11 \geq 18$ _____

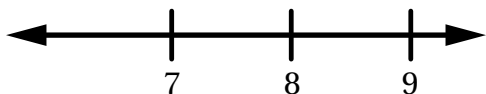

5. $-6x > 18$ _____

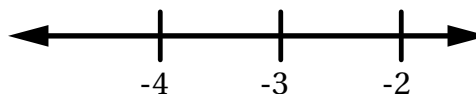

6. $x - 12 \geq -7$ _____

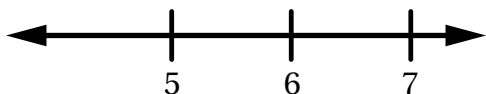

7. $-5x > -30$ _____

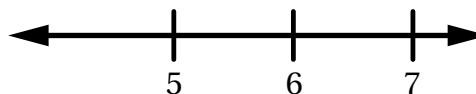

Check



Solve and graph the solution to $-4x < 8$.

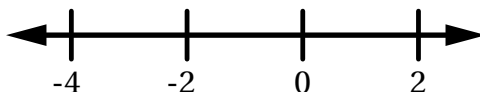

Goal

Solve linear equations that involve positive and negative numbers.

Standard

MA.7.AR.2.1



Modeled Review

Point to Avery’s work and **ask**:

- “How did Avery determine the boundary point?”
- “Why did Avery substitute 0 and 9 into the inequality?”
- “How does testing numbers help to determine which inequality symbol to use?”

Reinforce Avery’s thinking by saying, “After finding the boundary point, test values to determine which inequality symbol makes the solution statement true.”



Guided Practice

Focus students’ attention on finding the boundary point and testing values on both sides of the point.

To scaffold their thinking, **say**:

- “Determine the boundary point.”
- “Choose numbers to the left and right of the boundary point and substitute them into the inequality.”
- “Decide which number satisfies the inequality. Based on this, determine the correct inequality sign to use.”

Name _____

Solving Inequalities

ML 6.15

Modeled Review

Solve and graph the solution to $x - 1 > 5$. Name: Priya

$x > 6$	$x - 1 = 5$	$x < 6$	$x > 6$
	$+1 \quad +1$	$0 - 1 > 5$	$(9) - 1 > 5$
	$x = 6$	$-1 > 5$	$8 > 5$
		False	True

Guided Practice

- Graph the solution to the inequality $3x \geq 9$ by finding the boundary point and testing values on both sides of the boundary point.

Moves	Work	
Move 1: Find the boundary point.	$\frac{3x}{3} = \frac{9}{3}$ $x = 3$	
Move 2: Test the values on both sides of the point and determine whether the statement is true or false.	Less than or equal to $3(\underline{2}) \geq 9$ $\underline{6} \geq 9$ False	Greater than or equal to $3(\underline{4}) \geq 9$ $\underline{12} \geq 9$ True
	Move 3: Graph the solution.	

Vocabulary

If needed, share the meaning of the terms with students.

inequality: A comparison statement that uses the symbols $<$ or $>$. Inequalities are used to represent the relationship between numbers, variables, or expressions that are not always equal.

solution to an inequality: All of the values of a variable that make that inequality true.



Guided Practice

A Emphasize that inequality signs that include 'equal to' should be represented with a shaded circle on the number line.

Key Takeaway:

Say, "Solving inequalities is similar to solving equations. The solutions to an inequality can be determined by first solving an equation, then testing whether the values on the left or right side of the boundary point make the inequality true."



Guided Practice

Solve and graph the solution to each of the inequalities.

2. $2x \leq -8$ $x \leq -4$



3. $x - 1 > -7$ $x > -6$



4. $x + 11 \geq 18$ $x \geq 7$



5. $-6x > 18$ $x < 3$



6. $x - 12 \geq -7$ $x \geq 5$



7. $-5x > -30$ $x < 6$



Check

Solve and graph the solution to $-4x < 8$.

$x > -2$

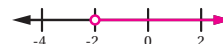

Reflection

Ask:

- "What steps can you take to graph the solutions to an inequality?"
- "How are solutions to an inequality different from an equation?"



Check: Recommended Next Steps

Almost there

If students need more support, consider having them revisit the problem in the Check. Then model graphing the solution by marking off the value on the number line that does not make statement true and circling the one that does. Invite them to use that information to determine how they should draw the arrow.

Got it!

If students need more practice, present students with the following problem and ask them to graph the solution:

$-7x \leq 42$

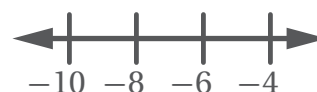

Unit 7

Mini-Lessons

Calculating Area of Parallelograms

ML 7.01



Modeled Review



Name: Amir

Calculate the area of the parallelogram.

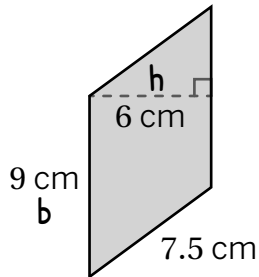

$$A = b \cdot h$$

$$A = 9 \cdot 6$$

$$A = 54$$

54 square centimeters



Guided Practice



1. Determine the base, height, and area of each parallelogram.

Parallelogram	Base (cm.)	Height (cm.)	Area $A = b \cdot h$
		2	6 square centimeters
	5		____ square centimeters



Guided Practice

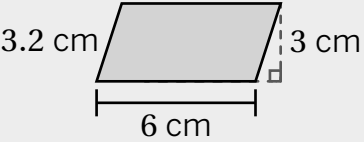
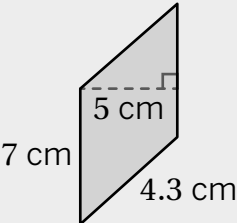
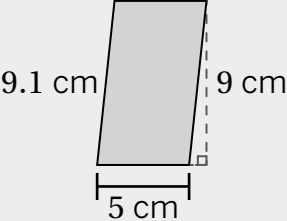

2. Determine the base, height, and area of each parallelogram.

Parallelogram	Base (cm.)	Height (cm.)	Work	Area
			$A = b \cdot h$	
				
				



Check



Calculate the area of the parallelogram.

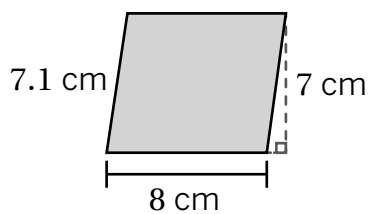

Goal

Calculate the area of a parallelogram without a grid, given its base and height.

Standard

MA.7.GR.1.1

Materials

highlighter (optional)



Modeled Review

Point to Amir's work and **ask**:

- "How did Amir determine the base of the parallelogram?"
- "How can a right angle help you determine the base-height pair?"
- "How did Amir calculate the area?"

Reinforce Amir's thinking by saying, "The formula to find the area of a parallelogram is $A = b \cdot h$. A base-height pair can be identified by the right angle formed between the base and the height."



Use a think aloud to model labeling the base and height of the parallelogram to stay organized.



Guided Practice

Focus students' attention on determining which measurements represent the base and height of each parallelogram.

To scaffold their thinking, **say**:

- "First, identify a base-height pair."
- "Next, substitute the values into the formula, $A = b \cdot h$."
- "Last, multiply the base and height to calculate the area."

Name _____

Calculating Area of Parallelograms

ML 7.01

Modeled Review

Name: Amir

Calculate the area of the parallelogram.

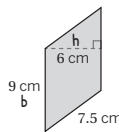

$$A = b \cdot h$$

$$A = 9 \cdot 6$$

$$A = 54$$

54 square centimeters

Guided Practice

1. Determine the base, height, and area of each parallelogram.

Parallelogram	Base (cm.)	Height (cm.)	Area $A = b \cdot h$
	3	2	6 square centimeters
	5	3	15 square centimeters

Vocabulary

If needed, share the meaning of the terms with students.

base of a parallelogram: The base is one side of a parallelogram. We can choose any side to be the base.

height: The height of a parallelogram is the shortest distance between a base and its opposite side.

area: Area measures the space inside a two-dimensional figure. It is expressed in square units.



Guided Practice

A Consider highlighting the right angle to show how it helps in identifying a base-height pair.

Key Takeaway:

Say, “When calculating the area of a parallelogram without a grid, you use measurements of a base and its matching height to determine the area.”



Guided Practice

2. Determine the base, height, and area of each parallelogram. **Sample work shown.**

Parallelogram	Base (cm.)	Height (cm.)	Work	Area
	6	3	$A = b \cdot h$ $A = 6 \cdot 3$ $A = 18$	18 square centimeters
	7	5	$A = b \cdot h$ $A = 7 \cdot 5$ $A = 35$	35 square centimeters
	5	9	$A = b \cdot h$ $A = 5 \cdot 9$ $A = 45$	45 square centimeters



Check

Calculate the area of the parallelogram. **Sample work shown.**

$A = b \cdot h$
 $A = 8 \cdot 7$
 $A = 56$
56 square centimeters

Reflection

Ask:

- “Describe how you can determine the area of any parallelogram.”
- “What strategy was helpful today?”



Check: Recommended Next Steps

Almost there

If students need more support, consider having them label the base and height of the parallelogram to ensure they use the correct measurements for calculating the area.

Got it!

If students need more practice, sketch the parallelogram and ask them to calculate the area.

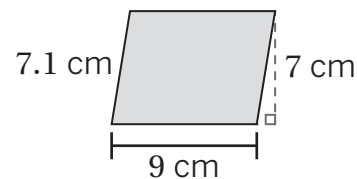

Calculating Areas of Complex Shapes

ML 7.04



Modeled Review



Name: Kai

What is the area of this shape?

$$\begin{aligned} \text{Area of circle} &= \pi r^2 \\ &= \pi 5^2 \\ &= 25\pi \\ \text{Area of square} &= lw \\ &= 10 \times 10 \\ &= 100 \end{aligned}$$

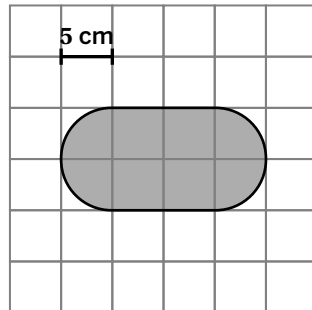

The shape is made up of a square and two semi-circles. Two semi-circles make one circle.

$$\text{Area of the shape} = 100 + 25\pi \text{ square centimeters}$$



Guided Practice



1. Calculate the area of the shape.

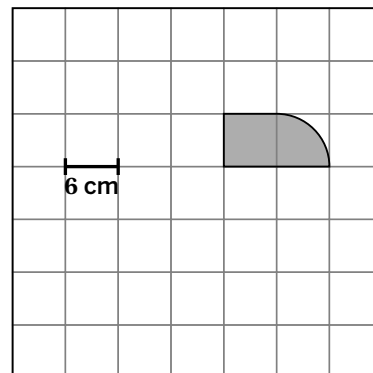
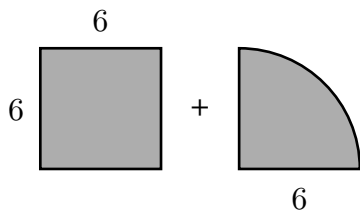

Area of square = _____ square centimeters

Area of a quarter circle = $\frac{\pi r^2}{4}$

= _____ square centimeters

Area of shape = ____ + ____ square centimeters



Guided Practice



Calculate the area of the given shape.

$$\text{Area of square} = lw$$

$$\text{Area of semi-circle} = \frac{\pi r^2}{2}$$

$$\text{Area of circle} = \pi r^2$$

$$\text{Area of quarter-circle} = \frac{\pi r^2}{4}$$

2.

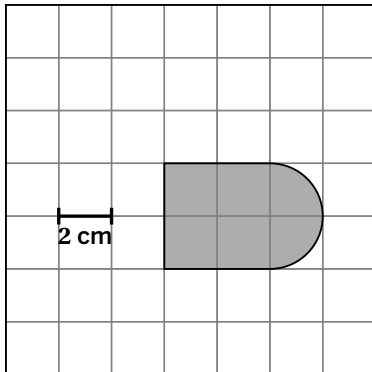

3.

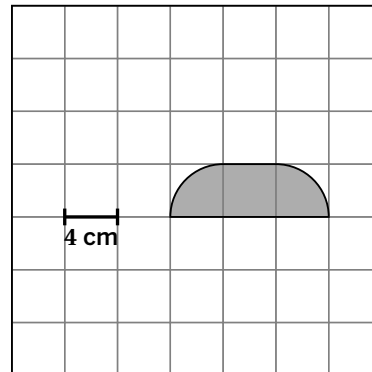

4.

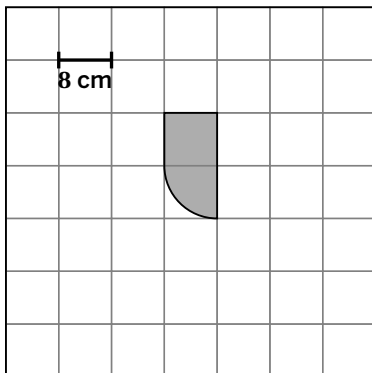

5.

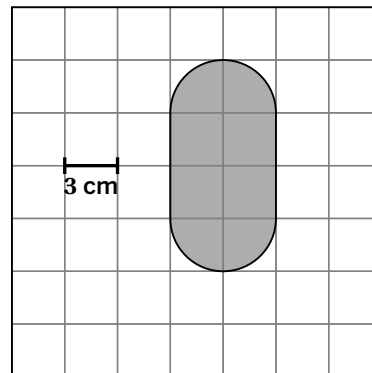

Check



Calculate the area of the shape.

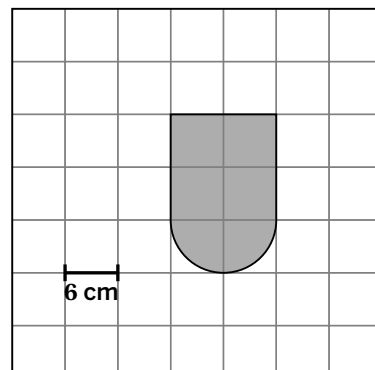

Goal

Calculate the area of a complex shape composed of fractions of circles.

Standard

MA.7.GR.1.4

Materials

coloring tools (optional)



Modeled Review

Point to Kai's work and **ask**:

- "How did Kai break up the complex shape?"
- "What shapes make up the complex shape?"
- "How did Kai calculate the area of the complex shape?"

Reinforce Kai's thinking by saying, "You can determine the area of complex shapes by decomposing them into squares and parts of circles."

ML/EL Model decomposing the shape into a square and two semi-circles. Show students how two semi-circles can be combined to form a circle.



Guided Practice

Focus students' attention on decomposing the complex shape to calculate the area.

To scaffold their thinking, **say**:

- "The shape can be broken up into other shapes."
- "Calculate the area of each shape."
- "To find the area of the complex shape, add the areas of all the shapes."

Name _____

Calculating Areas of Complex Shapes

ML 7.04



Modeled Review



What is the area of this shape? Name: Kai _____

$$\begin{aligned} \text{Area of circle} &= \pi r^2 \\ &= \pi 5^2 \\ &= 25\pi \\ \text{Area of square} &= lw \\ &= 10 \times 10 \\ &= 100 \end{aligned}$$

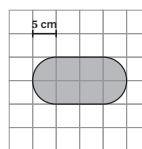

The shape is made up of a square and two semi-circles. Two semi-circles make one circle.

Area of the shape = $100 + 25\pi$ square centimeters



Guided Practice



1. Calculate the area of the shape.

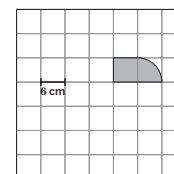
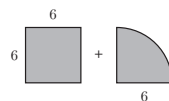

Area of square = 36 square centimeters

Area of a quarter circle = $\frac{\pi r^2}{4}$
= 9π square centimeters

Area of shape = $36 + 9\pi$ square centimeters

85

© Amplify Education, Inc. and its licensors

Vocabulary

If needed, share the meaning of the term with students.

circle: A shape made out of all the points that are the same distance from a center.



Guided Practice

A Invite students to decompose the shapes into smaller, familiar shapes such as squares and semi-circles. Ask them to shade these smaller shapes in different colors.

Note: Students can leave their answer as an expression that includes pi, such as $50 + 16\pi$.

Key Takeaway:

Say, “Decomposing shapes into squares and parts of circles can help determine their total area.”



Guided Practice

Calculate the area of the given shape. **Sample responses shown.**

Area of square = lw	Area of semi-circle = $\frac{\pi r^2}{2}$
Area of circle = πr^2	Area of quarter-circle = $\frac{\pi r^2}{4}$

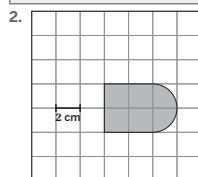

$16 + 2\pi$ square centimeters

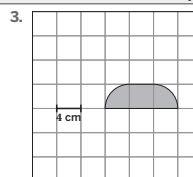

$16 + 8\pi$ square centimeters

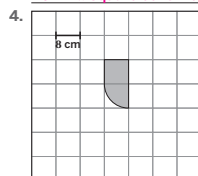

$64 + 16\pi$ square centimeters

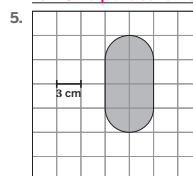

$36 + 9\pi$ square centimeters



Check

Calculate the area of the shape. **Sample response shown.**

$144 + 18\pi$ square centimeters

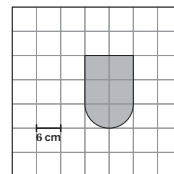

Reflection

Ask:

- “How does breaking up the complex shape help calculate the area?”
- “How did you overcome a hard problem today?”



Check: Recommended Next Steps

Almost there

If students need more support, ask them to create a t-chart for the shapes that make up the complex shape. Then have them use the t-chart to organize their work.

Got it!

If students need more practice, ask them how the area in Problem 5 would change if the scale was 8 centimeters.

Calculating Volumes of Cylinders

ML 7.06



Modeled Review



Name: Clare

Calculate the volume of the cylinder.

$$V = \pi r^2 h$$

$$V = \pi(1)^2(6)$$

$$V = 6\pi$$

6π cubic units

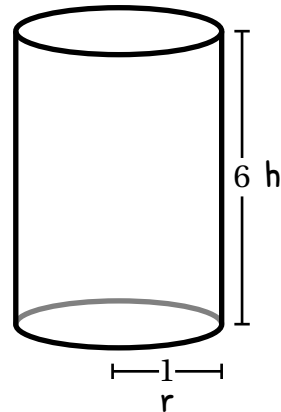

Guided Practice



Write an equation to find the volume, V , of each cylinder.

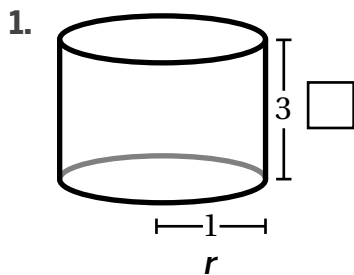

$$V = \pi r^2 h$$

$$V = \pi(1)^2(\underline{\quad})$$

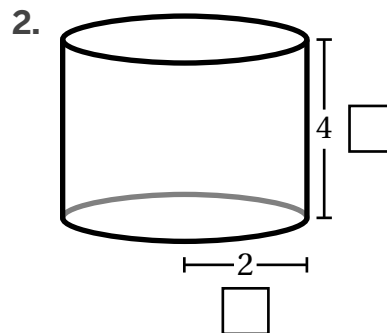

$$V = \pi r^2 h$$

$$V = \underline{\hspace{2cm}}$$



Guided Practice

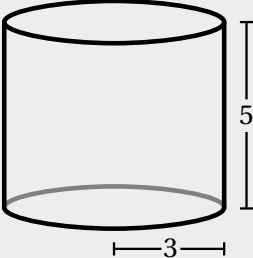
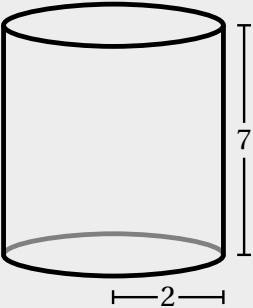
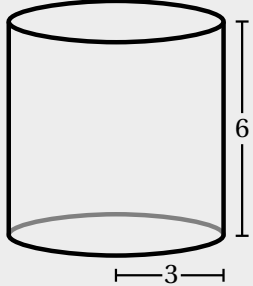

3. Calculate the volume, V , of each cylinder using the formula.

Cylinder	Formula $V = \pi r^2 h$	Volume
		
		
		



Check



Calculate the volume of the cylinder.

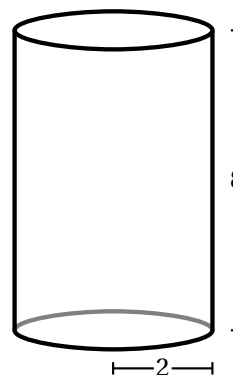

Goal

Calculate the volume of a cylinder given its height and radius.

Standard

MA.7.GR.2.3

Materials

image of a cylinder (optional)



Modeled Review

Point to Clare's work and **ask**:

- "How did Clare know which dimensions to label as the radius and height?"
- "What does it mean to square a number?"
- "Why does Clare square the radius first?"

Reinforce Clare's thinking by saying, "Labeling the radius and height of the cylinder can help organize the dimensions given to efficiently calculate the volume of a cylinder."

ML/EL Consider modeling, or inviting a student to model, annotating the problem to make sense of it.



Guided Practice

Focus students' attention on writing the formula with the given radius and height to determine the volume of a cylinder.

To scaffold their thinking, **say**:

- "Label the radius and height of the cylinder."
- "Substitute the dimensions accordingly into the formula."
- "Leave your answer in terms of pi."

Name _____

ML 7.06

Calculating Volumes of Cylinders

Modeled Review

Name: **Clare**

Calculate the volume of the cylinder.

$$V = \pi r^2 h$$

$$V = \pi (1)^2 (6)$$

$$V = 6\pi$$

6π cubic units

Guided Practice

Write an equation to find the volume, V , of each cylinder.

1.

$$V = \pi r^2 h$$

$$V = \pi (1)^2 (3)$$

2.

$$V = \pi r^2 h$$

$$V = \pi (2)^2 (4)$$

89 © Amplify Education, Inc and its licensors



Guided Practice

A Consider sharing a picture of a cylinder to increase access to the task. For example, show students a can of soup and ask them to point out the height and radius.

Note: Students can use either $V = Bh$ or $V = \pi r^2 h$ to calculate the volume of a cylinder.

Key Takeaway:

Say, “The volume of a cylinder can be found by multiplying the area of its base by its height, and is represented by the formulas $V = \pi r^2 h$ and $V = Bh$.”



Guided Practice

3. Calculate the volume, V , of each cylinder using the formula.

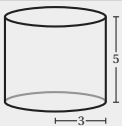
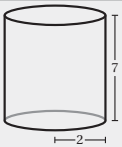
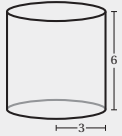
Cylinder	Formula $V = \pi r^2 h$	Volume
	$V = \pi(3)^2(5)$	45π cubic units
	$V = \pi(2)^2(7)$	28π cubic units
	$V = \pi(3)^2(6)$	54π cubic units



Check

Calculate the volume of the cylinder.

32π cubic units

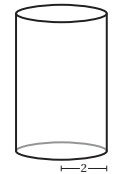

Reflection

Ask:

- “How does knowing the area of a circular base help calculate the volume of a cylinder?”
- “What is something you weren’t sure about at the start of the lesson but understand now?”



Check: Recommended Next Steps

Almost there

If students need more support, consider having them write the radius twice in the formula for finding the volume of a cylinder, instead of squaring it. This approach helps students understand the meaning behind the calculation, preventing them from simply multiplying the radius by two.

Got it!

If students need more practice, sketch the following cylinder and ask them to calculate its volume.

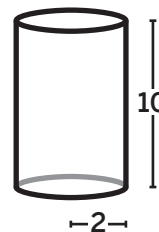

Unit 8

Mini-Lessons

Predicting Sample Spaces Using Proportional Relationships

ML 8.03



Modeled Review



100 blocks were picked one at a time, and the results are shown in the histogram.

A new bag has 5 blocks. Some blocks are black and the others are gray. Based on the results of the histogram, how many blocks do you think are black?

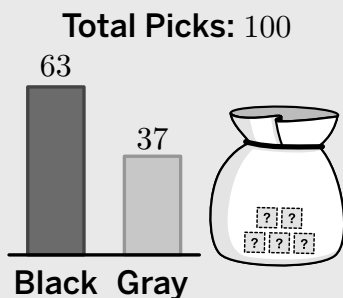

Amir's work

$$\frac{63}{100} = \frac{x}{5}$$

$$5 \cdot 0.63 = \frac{x}{5} \cdot 5$$

$$3.15 = x$$

$$x \cong 3$$

3 blocks

Axel's work

$$\frac{63}{100} \cong 60\%$$

$$x \cong 0.60 \cdot 5$$

$$x \cong 3$$

3 blocks



Guided Practice



10 blocks were picked one at a time, and the results are shown in the histogram.

1. A new bag has 4 blocks. Some are black and some are gray. Based on the results of the histogram, how many blocks do you think are gray?

$$\frac{\quad}{10} = \underline{\quad} \%$$

$$x = \underline{\quad} \cdot 4$$

$$x = \underline{\quad}$$

$$x \cong \underline{\quad}$$

 blocks

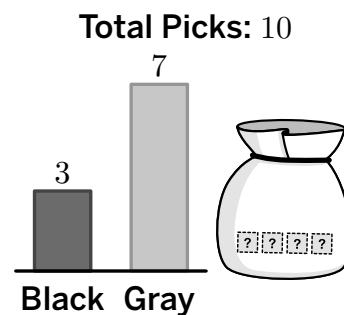



Guided Practice



100 blocks were picked one at a time, and the results are shown in the histogram.

- A new bag has 8 blocks. Some are black and some are gray. Based on the results of the histogram, how many blocks do you think are black?

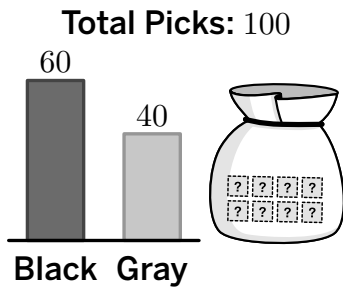

- The bag has 10 blocks. Some are black and some are gray. Based on the results of the histogram, how many blocks do you think are gray?

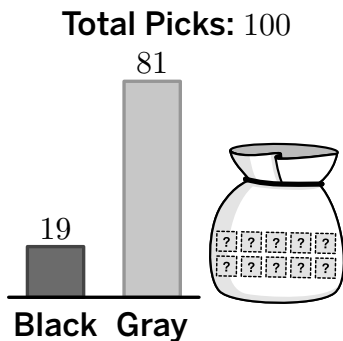

Check



100 blocks were picked one at a time, and the results are shown in the histogram.

A new bag has 6 blocks. Some blocks are black and the others are gray. Based on the results of the histogram, how many blocks do you think are black?

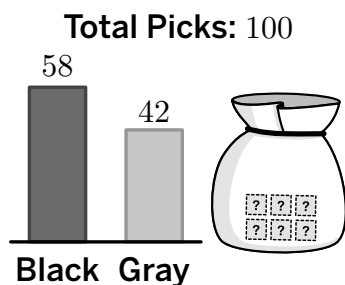

Goal

Use proportional reasoning and repeated experiments to calculate probability.

Standard

MA.7.DP.2.3

Materials

cubes (optional)



Modeled Review

Point to the Modeled Review and **ask**:

- “How are Amir’s and Axel’s strategies alike? Different?”
- “How did both Amir and Axel determine that the number of black blocks was probably 3?”
- “What do you think is helpful about each strategy?”

Reinforce the goal by saying, “The constant of proportionality from experiments can be used to make predictions.”



Guided Practice

Focus students’ attention on using the constant of proportionality to make predictions.

To scaffold their thinking, **say**:

- “First, identify what needs to be predicted.”
- “Next, calculate the constant of proportionality.”
- “Then, multiply the constant of proportionality by the total number of blocks.”
- “Finally, round your answer to the nearest whole number if the prediction does not make sense.”

Name _____

Predicting Sample Spaces Using Proportional Relationships

ML 8.03



Modeled Review

100 blocks were picked one at a time, and the results are shown in the histogram.

A new bag has 5 blocks. Some blocks are black and the others are gray. Based on the results of the histogram, how many blocks do you think are black?

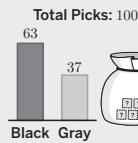

Amir’s work

$$\frac{63}{100} = \frac{x}{5}$$

$$5 \cdot 0.63 = \frac{x}{5} \cdot 5$$

$$3.15 = x$$

$$x \approx 3$$

3 blocks

Axel’s work

$$\frac{63}{100} \approx 60\%$$

$$x \approx 0.60 \cdot 5$$

$$x \approx 3$$

3 blocks



Guided Practice

10 blocks were picked one at a time, and the results are shown in the histogram.

1. A new bag has 4 blocks. Some are black and some are gray. Based on the results of the histogram, how many blocks do you think are gray?

$$\frac{7}{10} = \frac{70}{100} \%$$

$$x = \frac{0.70}{100} \cdot 4$$

$$x = \frac{2.8}{100}$$

$$x \approx 3$$

3 blocks

Total Picks: 10

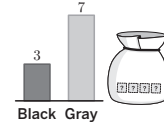

Vocabulary

If needed, share the meaning of the term with students.

constant of proportionality: In a proportional relationship, the number used to multiply the values for one quantity to get the values for the other quantity is called the constant of proportionality.



Guided Practice

A Provide students with cubes that can be used to replicate the mystery blocks in each problem. The cubes will serve as a hands-on tool to help clarify the solution students are working toward.

ML/EL Use a think aloud as you round to the nearest whole number by checking the digit after the decimal point. If it's 5 or greater, round up; otherwise, round down.

Key Takeaway:

Say, "The constant of proportionality can be calculated using the results from experiments to help make predictions."



Guided Practice

100 blocks were picked one at a time, and the results are shown in the histogram.

2. A new bag has 8 blocks. Some are black and some are gray. Based on the results of the histogram, how many blocks do you think are black?

Total Picks: 100

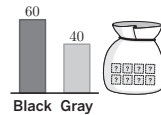

5 blocks

3. The bag has 10 blocks. Some are black and some are gray. Based on the results of the histogram, how many blocks do you think are gray?

Total Picks: 100

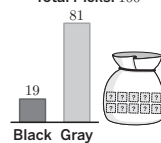

8 blocks



Check

100 blocks were picked one at a time, and the results are shown in the histogram.

A new bag has 6 blocks. Some blocks are black and the others are gray. Based on the results of the histogram, how many blocks do you think are black?

Total Picks: 100

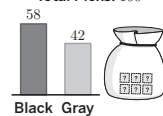

3 blocks

Reflection

Ask:

- "Describe your favorite strategy when predicting sample spaces using a constant of proportionality."
- "How did you overcome a hard problem today?"



Check: Recommended Next Steps

Almost there

If students need more support, consider creating an anchor chart that outlines the steps for determining the constant of proportionality to aid in making predictions.

Got it!

If students need more practice, have them use the histogram from Problem 3 to determine how many blocks would be black if there are 5 blocks in the bag.

Calculating Measures of Center and Spread

ML 8.09



Modeled Review



Name: Tristan

The line plot shows the number of text messages Deven sent every day for 12 days. Calculate the mean, median, and range of this data.

Number of text messages Deven sent

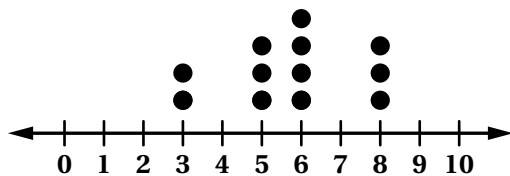

To find the mean, I divide the total number of texts (69) by the number of days (12).
 To find the median, I counted in from each side to find the number in the middle of the data.
 To find the range, I subtract the smallest value (3) from the largest value (8).

$$\text{Mean} = \frac{2(3) + 5(3) + 6(4) + 8(3)}{12} = \frac{69}{12} = 5.75$$

$$\text{Range} = 8 - 3 = 5 \text{ texts}$$

Median = The middle number of 12 numbers is halfway between the 6th and 7th number, which is 6 texts.



Guided Practice



- The line plot shows the number of books Jin read each month for 7 months. Calculate the mean, median, and range of this data.

Number of books Jin read

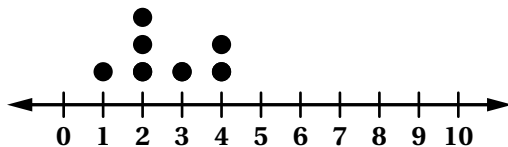

$$\text{Mean} = \frac{1(\quad) + 2(\quad) + 3(\quad) + 4(\quad)}{7} = \frac{\square}{7} \approx \underline{\quad}$$

Median = The middle value is _____.

$$\text{Range} = \underline{\quad} - \underline{\quad} = \underline{\quad}$$



Guided Practice



2. The line plot shows the number of homework assignments Neel completed each day for 5 days. Calculate the mean, median, and range of this data.

Number of assignments Neel completed

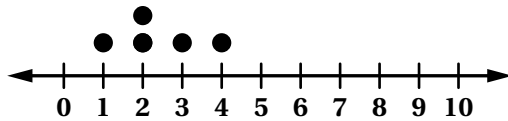

Mean = _____

Median = _____

Range = _____

3. The line plot shows the number of sales Peter made each day for 6 days. Calculate the mean, median, and range of this data.

Number of sales Peter made

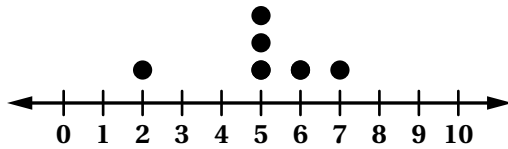

Mean = _____

Median = _____

Range = _____



Check



The line plot shows the number of birds Tyler saw each day for 6 days. Calculate the mean, median, and range of this data.

Number of birds Tyler saw

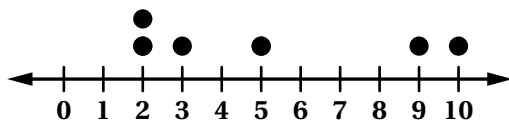

Mean = _____

Median = _____

Range = _____

Goal

Calculate the mean, median, and range of a data set.

Standard

MA.7.DP.1.1

Materials

calculator (optional)



Modeled Review

Point to Tristan's work and **ask**:

- "Where did Tristan find the numbers he added?"
- "How did Tristan determine the median of the data?"
- "What does the range of 5 represent?"

Reinforce Tristan's thinking by saying, "The mean can be calculated by adding all of the number of text messages together and dividing by the total number of text messages."



Discuss the vocabulary mean, median, range.



Guided Practice

Focus students' attention on calculating the mean for the data on the line plot.

To scaffold their thinking, **say**:

- "First, count the number of books over each dot on the line plot and multiply them by the value of the dot."
- "Then, divide this total number of books read by the total number of months, 7."

Name _____

Calculating Measures of Center and Spread

ML 8.09



Modeled Review



Name: **Tristan**

The line plot shows the number of text messages Deven sent every day for 12 days. Calculate the mean, median, and range of this data.

Number of text messages Deven sent



To find the mean, I divide the total number of texts (69) by the number of days (12).
To find the median, I counted in from each side to find the number in the middle of the data.
To find the range, I subtract the smallest value (3) from the largest value (8).

Mean = $\frac{2(3) + 3(5) + 4(6) + 3(8)}{12} = \frac{69}{12} = 5.75$

Range = $8 - 3 = 5$ texts

Median = The middle number of 12 numbers is halfway between the 6th and 7th number, which is 6 texts.



Guided Practice



1. The line plot shows the number of books Jin read each month for 7 months. Calculate the mean, median, and range of this data.

Number of books Jin read

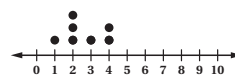

Mean = $\frac{1(1) + 2(2) + 3(3) + 1(4)}{7} = \frac{\quad}{7} \approx \quad$

Median = The middle value is 2.

Range = 4 - 1 = 3

Mean anno: $\frac{1(1) + 2(3) + 3(1) + 4(2)}{7} = \frac{18}{7} \approx 2.6$

Vocabulary

If needed, share the meaning of the terms with students.

mean: The arithmetic average of a set of numbers found by dividing the sum of all values by the number of values. It is a measure of central tendency.

median: The middle of an ordered list of values. It is a measure of central tendency.

range: The difference between the highest value and lowest value of a data set.



Guided Practice

A Consider providing students with calculators to efficiently calculate the mean.

Key Takeaway:

Say, “The mean is the value found by finding the sum of all of the data values and dividing it by the total number of data points.”



Guided Practice

2. The line plot shows the number of homework assignments Neel completed each day for 5 days. Calculate the mean, median, and range of this data.

Number of assignments Neel completed Mean = $\frac{1(1) + 2(2) + 3(1) + 4(1)}{5} = \frac{12}{5} \approx 2.4$



Median = 2

Range = 3

3. The line plot shows the number of sales Peter made each day for 6 days. Calculate the mean, median, and range of this data.

Number of sales Peter made Mean = $\frac{2(1) + 5(3) + 6(1) + 7(1)}{5} = \frac{30}{5} \approx 6$



Median = 5

Range = 5



Check

The line plot shows the number of birds Tyler saw each day for 6 days. Calculate the mean, median, and range of this data.

Number of birds Tyler saw Mean = $\frac{2(2) + 3(1) + 5(1) + 9(1) + 10(1)}{6} = \frac{31}{6} \approx 5.2$

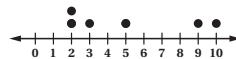

Median = 4

Range = 8

Reflection

Ask:

- “What step did you find most challenging when calculating the mean, median, and range?”
- “Reflect on your learning today. What were you most proud of?”



Check: Recommended Next Steps

Almost there

If students need more support, consider revisiting the problem in the Check and using a think-aloud to finding the mean from the dot plot.

Got it!

If students need more practice, sketch the dot plot and ask them to calculate the mean.

Number of miles employees travel to work

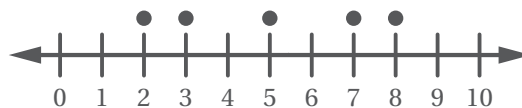

Predicting Population Using Sample Data

ML 8.11



Modeled Review

Name: Caleb

20 random students from Median Middle School were asked what superpower they wanted. The results are shown in the table. Median Middle School has 500 students. Estimate the total number of students who prefer teleportation.

$$\frac{4}{20} = \frac{x}{500}$$

$$500 \cdot 0.2 = \frac{x}{500} \cdot 500$$

$$100 = x$$

100 students

Superpower	Number of students
Teleportation	4
Flight	3
Super strength	3
Time travel	5
Invisibility	5



Guided Practice



1. 10 random 7th grade students from Birchwood Middle School were asked about their favorite type of pet. The results are shown in the table. Birchwood Middle School has 50 students in 7th grade. Estimate the total number of students who prefer fish.

$$\frac{\quad}{10} = \frac{x}{\quad}$$

$$\underline{\quad} \cdot \underline{\quad} = \frac{x}{\quad} \cdot \underline{\quad}$$

$$\underline{\quad} = x$$

 students

Pet	Number of students
Dogs	6
Cats	3
Fish	1



Guided Practice



2. 15 random students from Pinecrest Academy were asked what their favorite type of music was. The results are shown in the table. Pinecrest Academy has 100 students. Estimate the total number of students who prefer country music.

_____ students

$$\frac{\quad}{\quad} = \frac{x}{\quad}$$

$$\frac{\quad}{\quad} \cdot \frac{\quad}{\quad} = \frac{x}{\quad} \cdot \frac{\quad}{\quad}$$

$$\frac{\quad}{\quad} = x$$

Music	Number of students
Pop	1
Rock	3
Hip-Hop	2
Country	9

3. 20 random students from Oakwood Elementary were asked what their favorite fruit was. The results are shown in the table. Oakwood Elementary has 400 students. Estimate the total number of students who prefer pineapple.

_____ students

Fruit	Number of students
Apples	5
Bananas	3
Oranges	3
Strawberries	5
Pineapple	4



Check



- 25 random students from Valley High School were asked what their favorite sport is. The results are shown in the table. Valley High School has 400 students. Estimate the total number of students who prefer basketball.

_____ students

Sport	Number of students
Soccer	8
Basketball	10
Baseball	3
Tennis	4

Goal

Estimate unknown information about a population using proportional reasoning.

Standard

MA.7.DP.1.3

Materials

graph paper (optional), highlighter (optional)



Modeled Review

Point to Caleb's work and **ask**:

- "How did Caleb use equivalent ratios to estimate the number of students who would prefer teleportation as a superpower?"
- "What steps did Caleb take to solve for the unknown value?"
- "Is Caleb's prediction reasonable? How do you know?"

Reinforce Caleb's thinking by saying, "The constant of proportionality can be used from the given sample to make accurate predictions."



Guided Practice

Focus students' attention on making a prediction using proportions.

To scaffold their thinking, **say**:

- "First, identify the given ratio in the sample."
- "Next, set up a proportion using the known ratio and the population you're predicting."
- "Last, solve the proportion and check if the prediction makes sense."

Name _____

Predicting Population Using Sample Data

ML 8.11



Modeled Review



Name: Caleb

20 random students from Median Middle School were asked what superpower they wanted. The results are shown in the table. Median Middle School has 500 students. Estimate the total number of students who prefer teleportation.

$$\frac{4}{20} = \frac{x}{500}$$

$$500 \cdot 0.2 = \frac{x}{500} \cdot 500$$

$$100 = x$$

100 students

Superpower	Number of students
Teleportation	4
Flight	3
Super strength	3
Time travel	5
Invisibility	5



Guided Practice



- 10 random 7th grade students from Birchwood Middle School were asked about their favorite type of pet. The results are shown in the table. Birchwood Middle School has 50 students in 7th grade. Estimate the total number of students who prefer fish.

$$\frac{1}{10} = \frac{x}{50}$$

$$50 \cdot 0.1 = \frac{x}{50} \cdot 50$$

$$5 = x$$

5 students

Pet	Number of students
Dogs	6
Cats	3
Fish	1

103

© Amplify Education, Inc and its licensors

Vocabulary

If needed, share the meaning of the terms with students.

equivalent ratios: Two ratios are equivalent if you can multiply each of the values in the first ratio by the same number to get the values in the second ratio.

proportional: Quantities are proportional if they form equivalent ratios.

sample: A part of a population.



Guided Practice

A Provide students with graph paper to organize their work.

ML/EL Consider using a highlighter to color-code and represent differing parts of the proportion (e.g., numerator and denominator) for clarity.

Key Takeaway:

Say, “The constant of proportionality from a sample helps us make accurate predictions about the entire population.”



Guided Practice

2. 15 random students from Pinecrest Academy were asked what their favorite type of music was. The results are shown in the table. Pinecrest Academy has 100 students. Estimate the total number of students who prefer country music.

60 students

$$\frac{9}{15} = \frac{x}{100}$$

$$100 \cdot 0.6 = \frac{x}{100} \cdot 100$$

$$60 = x$$

Music	Number of students
Pop	1
Rock	3
Hip-Hop	2
Country	9

3. 20 random students from Oakwood Elementary were asked what their favorite fruit was. The results are shown in the table. Oakwood Elementary has 400 students. Estimate the total number of students who prefer pineapple.

80 students

Fruit	Number of students
Apples	5
Bananas	3
Oranges	3
Strawberries	5
Pineapple	4



Check

- 25 random students from Valley High School were asked what their favorite sport is. The results are shown in the table. Valley High School has 400 students. Estimate the total number of students who prefer basketball.

160 students

Sport	Number of students
Soccer	8
Basketball	10
Baseball	3
Tennis	4

Reflection

Ask:

- “Describe how you could use a sample and proportional reasoning to estimate information about a population.”
- “Reflect on your learning today. What were you most proud of?”



Check: Recommended Next Steps

Almost there

If students need more support, consider having them revisit the Check. Then, model identifying the given ratio, setting up the proportion using the known ratio and population, and solving the proportion and checking to make sure the prediction makes sense.

Got it!

If students need more practice, have them revisit Problem 3 and predict the total populations that favored the other fruits.

**Prerequisite Skills
and Concepts**

Mini-Lessons

Solving Problems Involving Area and Perimeter

ML 6.21



Modeled Review

Name: Tristan

A square has a perimeter of 252 inches. What is the length of each side?

$$\begin{array}{l} 252 \div 4 = s \\ \downarrow \quad \swarrow \\ 240 + 12 \end{array}$$

$$\begin{array}{l} 240 \div 4 = \textcircled{60} \\ 12 \div 4 = \textcircled{3} \\ 60 + 3 = 63 \end{array}$$

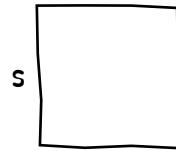

answer: 63 inches



Guided Practice



1. A rectangle has an area of 446 square inches. The length is 2 inches. What is the width?

answer: _____

2. A square has a perimeter of 136 inches. What is the length of each side?

answer: _____



Guided Practice



3. A rectangle measures 3 feet wide and 257 feet long. What is the area of the rectangle?

answer: _____

4. A rectangle measures 32 feet wide and 26 feet long. What is the area of the rectangle?

answer: _____



Check



A rectangle measures 17 inches wide and 48 inches long. What is the area of the rectangle?

answer: _____

Goal

Solve problems involving perimeter and area.

Standard

MA.4.GR.2.1



Modeled Review

Point to Tristan's work and ask:

- "What information was known? Unknown?"
- "What steps did Tristan take to find the side lengths?"
- "Why did Tristan divide 252 by 4 to find the side lengths of the square?"

Reinforce Tristan's thinking by saying, "You can use what you know about squares and rectangles to find missing side lengths if you know the perimeter or area."

ML/EL Display an anchor chart with area and perimeter examples and formulas. Explain the information to students, emphasizing the differences between area and perimeter.



Guided Practice

Focus students' attention on determining the unknown side lengths.

To scaffold their thinking, **ask**:

- "What do you know about the side lengths of a rectangle? Square?"
- "How can you use the known information to determine the unknown side lengths?"

Name _____

Solving Problems Involving Area and Perimeter
ML 6.21

Modeled Review

Name: Tristan

A square has a perimeter of 252 inches. What is the length of each side?

$252 \div 4 = s$
 \downarrow
 $240 \div 12$

$240 \div 4 = 60$
 $12 \div 4 = 3$
 $60 + 3 = 63$

s

answer: 63 inches

Guided Practice

1. A rectangle has an area of 446 square inches. The length is 2 inches. What is the width? **Sample work shown.**

$400 \div 2 = 200$
 $40 \div 2 = 20$
 $6 \div 2 = 3$

200
 20
 $+ 3$

 223

answer: 223 inches

2. A square has a perimeter of 136 inches. What is the length of each side? **Sample work shown.**

$136 \div 4 = s$
 \downarrow
 $120 \div 16$

$120 \div 4 = 30$
 $16 \div 4 = 4$

$30 + 4 = 34$

answer: 34 inches

109 © Amplify Education, Inc and its licensors

Vocabulary

If needed, share the meaning of the terms with students.

area: A measurement of the space inside a two-dimensional shape.

perimeter: The total length of the boundary of a two-dimensional shape.



Guided Practice

A Invite students to draw a rectangle labeling the known side lengths to help them visualize the problem and determine the area.

Key Takeaway:

Say, “Knowing the formulas for area and perimeter can help you figure out missing side lengths. If you are given the side lengths, you can use them to calculate the area or perimeter.”



Guided Practice

3. A rectangle measures 3 feet wide and 257 feet long. What is the area of the rectangle? **Sample work shown.**

	200	50	7	
3	200 × 3 = 600	50 × 3 = 150	7 × 3 = 21	
				600
				150
				+ 21
				771

answer: 771 square feet

4. A rectangle measures 32 feet wide and 26 feet long. What is the area of the rectangle? **Sample work shown.**

	30	2	
20	30 × 20 = 600	2 × 20 = 40	
			600
			40
			180
6	30 × 6 = 180	2 × 6 = 12	
			+ 12
			832

answer: 832 square inches



Check

A rectangle measures 17 inches wide and 48 inches long. What is the area of the rectangle? **Sample work shown.**

	40	8	
10	40 × 10 = 400	8 × 10 = 80	
			400
			80
			280
7	40 × 7 = 280	8 × 7 = 56	
			+ 56
			816

answer: 816 square inches

Reflection

Ask:

- “How can you determine the area of a figure when some side lengths are missing?”
- “How did today’s learning connect to your previous learning?”



Check: Recommended Next Steps

Almost there

If students need more support, consider using a think-aloud to model the step-by-step process for finding the area in Problem 4. Then invite students to revisit the Check.

Got it!

If students need more practice, invite them to determine the missing measurement.

- A square has a perimeter of 732 feet. What is the length of each side?
- A rectangle has a length of 58 inches and a width of 23 inches. What is the area of the rectangle?

Identifying Acute, Obtuse, Right, and Straight Angles

ML 7.09



Modeled Review



Name: Avery

Identify each angle as acute, right, obtuse, or straight. Then record the angle measure.

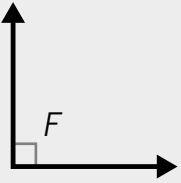
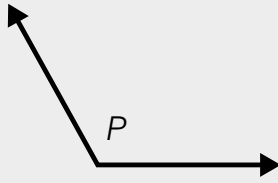
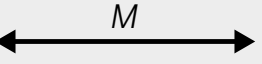
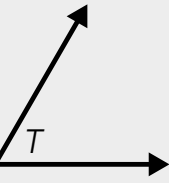

			
right 90°	obtuse 120°	straight 180°	acute 60°



Guided Practice

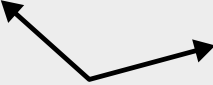

- Complete the table by labeling each angle. Use a protractor to measure if it is helpful.

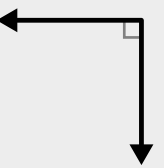
	Acute, right, or obtuse	Greater than, less than, or equal to 90°
		greater than 90°
	acute	
		equal to 90°



Guided Practice

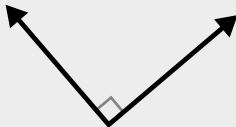
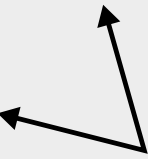
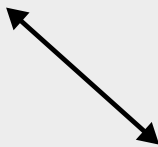
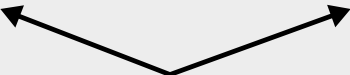

2. Identify each angle as acute, right, obtuse, or straight. Then record the angle measure.

	Acute, right, obtuse, or straight	Measurement in degrees
		
		
		
		



Check

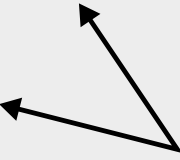
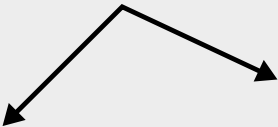

- Identify each angle as acute, right, obtuse, or straight. Then record the angle measure.

	Acute, right, obtuse, or straight	Measurement in degrees
		
		

Goal

Identify acute, obtuse, right, and straight angles and record the angle measure in degrees.

Standard

MA.4.GR.1.1

Materials

protractor



Modeled Review

Point to Avery's work and **ask**:

- "What measures would classify an angle as acute? Obtuse? Right? Straight?"
- "What feature do you see on the right angle that is different from the other angles? What do you think that means?"

Reinforce the goal by saying, "Right angles measure exactly 90 degrees, and straight angles measure exactly 180 degrees. Acute angles measure less than 90 degrees, and obtuse angles measure greater than 90 degrees but less than 180 degrees."



Use arm gestures to represent the angles as you share the definition of each term.



Guided Practice

Focus students' attention on labeling each angle.

To scaffold their thinking, **ask**:

- "How can you locate 90° on the protractor?"
- "How will you determine if each angle is more, less than, or equal to 90° using a protractor?"
- "Is the angle acute, right, obtuse, or straight? How do you know?"

Name _____

Identifying Acute, Obtuse, Right, and Straight Angles

ML 7.09

Modeled Review

Name: Avery

Identify each angle as acute, right, obtuse, or straight. Then record the angle measure.

right 90°	obtuse 120°	straight 180°	acute 60°

Guided Practice

1. Complete the table by labeling each angle. Use a protractor to measure if it is helpful.

	Acute, right, or obtuse	Greater than, less than, or equal to 90°
	obtuse	greater than 90°
	acute	less than 90°
	right	equal to 90°

Vocabulary

If needed, share the meaning of the terms with students.

acute angle: An angle with a measure of less than 90 degrees.

obtuse angle: An angle with a measure greater than 90 degrees but less than 180 degrees.

right angle: An angle that measures 90 degrees.

straight angle: An angle that measures 180 degrees.



Guided Practice

A Demonstrate to students how to properly align the protractor and determine which set of numbers to use to find the measurement of an angle before they complete Problem 2.

Note: Close, reasonable measurements are acceptable.

Key Takeaway:

Say, “Angles can be identified as acute, right, obtuse, or straight angles based on their size in degrees.”



Guided Practice

2. Identify each angle as acute, right, obtuse, or straight. Then record the angle measure.

	Acute, right, obtuse, or straight	Measurement in degrees
	right	90°
	acute	60°
	straight	180°
	obtuse	140°



Check

Identify each angle as acute, right, obtuse, or straight. Then record the angle measure.

	Acute, right, obtuse, or straight	Measurement in degrees
	acute	40°
	obtuse	110°

Reflection

Ask:

- “How could you use your arms to show an angle that is acute? Obtuse? Right? Straight?”
- “How did you overcome a hard problem today?”



Check: Recommended Next Steps

Almost there

If students need more support, consider having them determine the measurement in degrees of the angles in Problem 1 using a protractor. Provide students with support and feedback as they measure each angle.

Got it!

If students need more practice, sketch a variety of angles. Then ask students to label each angle as acute, obtuse, right, or straight and measure each using a protractor.

Using the Structure of Rectangular Prisms to Determine Volume

ML 1.04



Modeled Review



Name: Gabriela

Determine the volume of the prism. Show or explain your thinking.

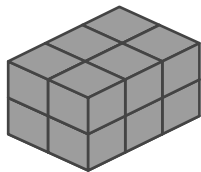

The bottom layer has 6 cubes.
There are 2 layers. 2 layers of 6 cubes is 12 cubes.

answer: 12 cubic units



Guided Practice

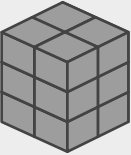
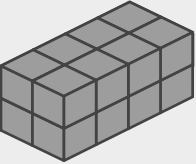
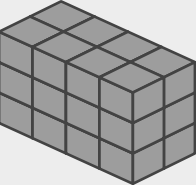

1. Complete the table.

Prism	Number of cubes in the bottom layer	Number of layers	Volume (cubic units)
	4	3	
	8		
			



Guided Practice



Determine the volume of each prism. Show or explain your thinking.

2.

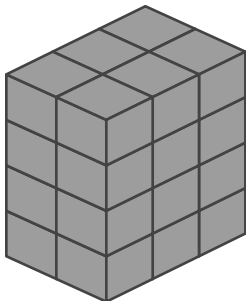

answer: _____

3.

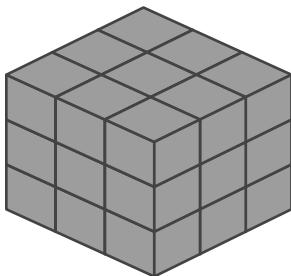

answer: _____



Check



Determine the volume of the prism. Show or explain your thinking.

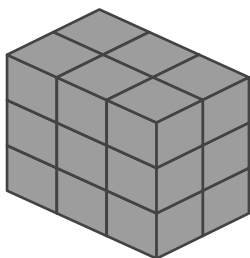

answer: _____

Goal

Use the layered structure of a rectangular prism to explain how to determine volume.

Standard

MA.5.GR.3.1

Materials

unit cubes (optional)



Modeled Review

Point to Gabriela's work and ask:

- "How did Gabriela know the bottom layer has 6 cubes?"
- "How did Gabriela know there are 2 layers?"
- "How would Gabriela's thinking change if the prism had 4 more layers?"
- "What steps did Gabriela take to determine the volume?"

Reinforce the goal by saying, "You can determine the volume of a rectangular prism shown in a two-dimensional image by using your understanding of layers composed of equal groups of unit cubes."



Guided Practice

Focus students' attention on the number of cubes in a layer and how they can use multiplication to find the volume.

To scaffold their thinking, **ask**:

- "How does the top layer help you to know the amount of cubes in the bottom layer?"
- "How can you use multiplication to find the volume?"

Name _____

Using the Structure of Rectangular Prisms to Determine Volume

ML 1.04

Modeled Review



Name: Gabriela

Determine the volume of the prism. Show or explain your thinking.



The bottom layer has 6 cubes.
There are 2 layers. 2 layers of 6 cubes is 12 cubes.

answer: 12 cubic units



Guided Practice



1. Complete the table.

Prism	Number of cubes in the bottom layer	Number of layers	Volume (cubic units)
	4	3	12 cubic units
	8	2	16 cubic units
	6	3	18 cubic units

117

© Amplify Education, Inc and its licensors

Vocabulary

If needed, share the meaning of the terms with students.

rectangular prism: A solid figure with 6 faces that are all rectangles.

unit cube: A cube, whose sides are 1 unit long, used to measure volume.

volume: The amount of space a three-dimensional figure takes up.



Guided Practice

A Provide access to unit cubes and have students build the prisms they see in the images.

Key Takeaway:

Say, “The volume of a rectangular prism can be determined by counting equal groups of any one layer. No matter which layer you use, the volume will be the same.”



Guided Practice



Determine the volume of each prism. Show or explain your thinking.

Sample work shown.

2.

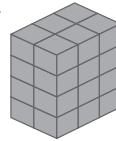

$$6 \times 4 = 24$$

answer: 24 cubic units

3.

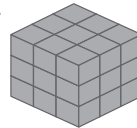

$$9 \times 3 = 27$$

answer: 27 cubic units



Check



Determine the volume of the prism. Show or explain your thinking.

Sample work shown.

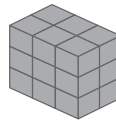

$$8 \times 3 = 24$$

answer: 27 cubic units

118

© Amplify Education, Inc and its licensors.

Reflection

Ask:

- “Does the volume of a prism change depending on which side of the prism you are viewing? Why or why not?”
- “How was the lesson helpful to you today?”



Check: Recommended Next Steps

Almost there

If students need more support, consider using unit cubes and have students build different rectangular prisms with specific dimensions and then calculating the volume.

Got it!

If students need more practice, consider having them determine the volume of each prism.

- A prism with 5 layers and 10 cubes on the bottom layer.
- A prism with 8 layers and 5 cubes on the bottom layer.

Using Clues to Determine the Volumes of Figures

ML 1.14



Modeled Review



Name: Clare

Use the clues to determine the volume of the figure. Show or explain your thinking.

Clues

- Prism B has a length of 3 inches, a width of 5 inches, and a height of 2 inches.
- The volume of Prism A is 2 times the volume of Prism B.

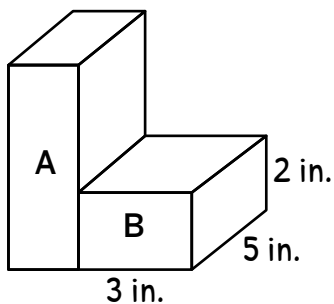

$$\text{Prism B: } 3 \times 5 \times 2 = 30$$

$$\text{Prism A: } 2 \times 30 = 60$$

$$\text{total volume: } 30 + 60 = 90$$

answer: 90 cubic inches



Guided Practice



1. Use the clues to complete the dimensions of Prism A and Prism B.

Clues

- The length of Prism A is twice the length of Prism B.
- The height of Prism A is half the width of Prism B.

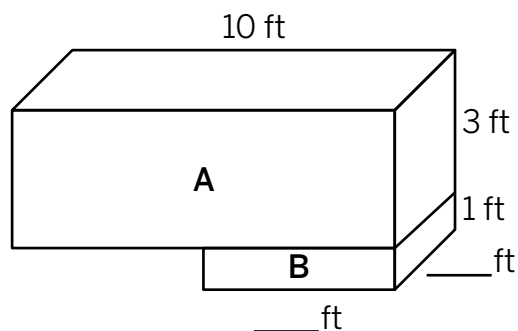



Guided Practice



2. Use the clues to determine the volume of the figure. Show or explain your thinking.

Clues

- Prism B has a length of 3 inches, a width of 2 inches, and a height of 9 inches.
- Prism A has a height of 3 inches.
- The width of each prism is the same.
- The length of Prism A and B is 8 inches combined.

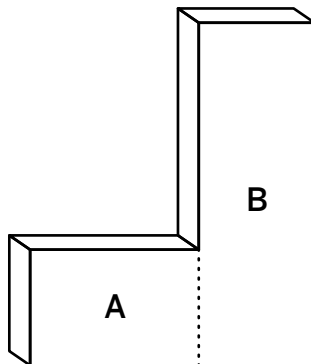

answer: _____



Check



- Use the clues to determine the volume of the figure. Show or explain your thinking.

Clues

- Prism A has a length of 6 inches, a width of 2 inches, and height of 2 inches.
- The volume of each prism is the same.

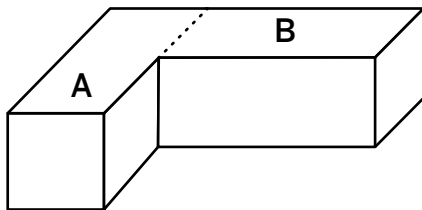

answer: _____

Goal

Determine the volume of a figure composed of rectangular prisms when given clues about the figure's attributes.

Standard

MA.5.GR.3.3



Modeled Review

Point to Clare's work and **ask**:

- "What did Clare determine from the first clue?"
- "What did Clare determine from the second clue?"

Reinforce the goal by saying, "After using the clues to label the diagram, Clare determined the volume of each prism and then added to determine the total volume."

ML/EL Read each clue aloud one at a time and guide students through annotating the figure.



Guided Practice

Focus students' attention using clues to determine the dimensions.

To scaffold their thinking, **ask**:

- "What is the length of Prism A?"
- "How could you use the length of Prism A to determine the length of Prism B?"
- "What is the height of Prism A?"
- "How could you use the height of Prism A to determine the width of Prism B?"

Name _____

Using Clues to Determine the Volumes of Figures

ML 1.14



Modeled Review



Name: Clare

Use the clues to determine the volume of the figure. Show or explain your thinking.

Clues

- Prism B has a length of 3 inches, a width of 5 inches, and a height of 2 inches.
- The volume of Prism A is 2 times the volume of Prism B.

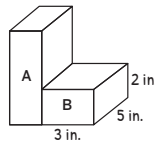

$$\text{Prism B: } 3 \times 5 \times 2 = 30$$

$$\text{Prism A: } 2 \times 30 = 60$$

$$\text{total volume: } 30 + 60 = 90$$

answer: 90 cubic inches



Guided Practice



1. Use the clues to complete the dimensions of Prism A and Prism B.

Clues

- The length of Prism A is twice the length of Prism B.
- The height of Prism A is half the width of Prism B.

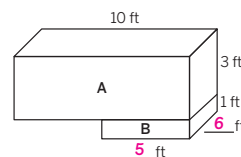

121

© Amplify Education, Inc. and its licensors.

Vocabulary

If needed, share the meaning of the term with students.

volume: The amount of space a three-dimensional figure takes up.



Guided Practice

A Direct students to take note of each clue, labeling the figure before reading the next clue.

Key Takeaway:

Say, “You can use what you know about the structure and volume of rectangular prisms to determine the volumes of figures composed of rectangular prisms, even when limited information is known.”



Guided Practice

2. Use the clues to determine the volume of the figure. Show or explain your thinking. **Sample work shown.**

Clues

- Prism B has a length of 3 inches, a width of 2 inches, and a height of 9 inches.
- Prism A has a height of 3 inches.
- The width of each prism is the same.
- The length of Prism A and B is 8 inches combined.

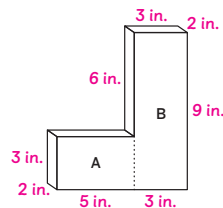

Prism A: $3 \times 2 \times 5 = 30$
 Prism B: $3 \times 2 \times 9 = 54$
 total volume: $30 + 54 = 84$
 answer: 84 cubic inches



Check

Use the clues to determine the volume of the figure. Show or explain your thinking. **Sample work shown.**

Clues

- Prism A has a length of 6 inches, a width of 2 inches, and height of 2 inches.
- The volume of each prism is the same.

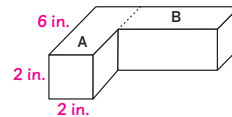

Prism A: $6 \times 2 \times 2 = 24$
 Prism B: 24
 total volume: $24 + 24 = 48$
 answer: 48 cubic inches

Reflection

Ask:

- “What did you learn about volume in this lesson? What would you like to know more about?”
- “What makes sense? What is still confusing?”



Check: Recommended Next Steps

Almost there

If students need more support, consider using Mini-Lesson 1.12: *Determining Unknown Edge Lengths of a Figure.*

Got it!

If students need more practice, have them determine the total volume of the figure in Problem 1.

Finding Products Using the Standard Algorithm With Composing in More Than One Place

ML 4.08



Modeled Review



Name: Jack

Determine the product using the standard algorithm.

$$583 \times 67 = \underline{39,061}$$

$$\begin{array}{r}
 4 1 \\
 5 2 \\
 5 8 3 \\
 \times 6 7 \\
 \hline
 4, 0 8 1 \\
 + 3 4, 9 8 0 \\
 \hline
 3 9, 0 6 1
 \end{array}$$



Guided Practice



Determine the product using the standard algorithm.

1. $749 \times 58 =$ _____

2. $326 \times 89 =$ _____

$$\begin{array}{r}
 2 4 \\
 3 7 \\
 7 4 9 \\
 \times 5 8 \\
 \hline
 5, 9 9 2 \\
 + 3 7, 4 5 0 \\
 \hline
 \boxed{}\boxed{}\boxed{}\boxed{}\boxed{}
 \end{array}$$

$$\begin{array}{r}
 2 5 \\
 3 2 6 \\
 \times 8 9 \\
 \hline
 2, 9 3 4 \\
 + \boxed{}\boxed{}\boxed{}\boxed{}0 \\
 \hline
 \boxed{}\boxed{}\boxed{}\boxed{}\boxed{}
 \end{array}$$



Guided Practice

A Provide students with lined paper oriented vertically to help organize the digits and products based on their value. Ensure that students align the products in their correct columns to help them keep track of the values as they add up the partial products to find the final product.

Key Takeaway:

Say, "Recording composed units above factors is a shorthand way to multiply single digits and add any composed units before recording the digits of the partial product."



Guided Practice

Determine the product using the standard algorithm.

3. $248 \times 75 = \underline{18,600}$

$$\begin{array}{r} 35 \\ 24 \\ 248 \\ \times 75 \\ \hline 1240 \\ + 17360 \\ \hline 18600 \end{array}$$

4. $395 \times 62 = \underline{24,490}$

$$\begin{array}{r} 53 \\ 11 \\ 395 \\ \times 62 \\ \hline 790 \\ + 23700 \\ \hline 24490 \end{array}$$

5. $417 \times 86 = \underline{35,862}$

$$\begin{array}{r} 15 \\ 14 \\ 417 \\ \times 86 \\ \hline 2502 \\ + 33600 \\ \hline 35862 \end{array}$$

6. $539 \times 94 = \underline{50,666}$

$$\begin{array}{r} 38 \\ 13 \\ 539 \\ \times 94 \\ \hline 2156 \\ + 48510 \\ \hline 50666 \end{array}$$



Check

Determine the product using the standard algorithm.

$462 \times 74 = \underline{34,188}$

$$\begin{array}{r} 41 \\ 2 \\ 462 \\ \times 74 \\ \hline 1848 \\ + 32340 \\ \hline 34188 \end{array}$$

Reflection

Ask:

- "How is composing units above the factors similar to how you composed units in previous lessons? How is it different?"
- "What is something you weren't sure about at the start of the lesson but understand now?"



Check: Recommended Next Steps

Almost there

If students need more support, consider creating a process/strategy anchor chart with students so they can use as a reference guide.

Got it!

If students need more practice, invite them to use the standard algorithm to determine the product for the following expressions:

- 429×26
- 639×48
- 794×53

Adding Decimals

ML 5.10



Modeled Review



Name: Priya

Determine the sum. Show your thinking.

$$5.3 + 14.78 = \underline{20.08}$$

$$\begin{array}{r} 11 \\ 14.78 \\ + 5.30 \\ \hline 20.08 \end{array}$$



Guided Practice



Determine the sum.

1. $25.18 + 1.5 =$ _____

$$\begin{array}{r} 25.18 \\ + 1.50 \\ \hline \square\square.\square\square \end{array}$$

2. $13.66 + 1.45 =$ _____

$$\begin{array}{r} 13.66 \\ + 1.45 \\ \hline \square\square.\square\square1 \end{array}$$

3. $72.93 + 4.7 =$ _____

$$\begin{array}{r} \square \\ 72.93 \\ + 4.70 \\ \hline \square\square.\square\square \end{array}$$

4. $51.24 + 9.07 =$ _____

$$\begin{array}{r} \square \\ 51.24 \\ + 9.07 \\ \hline \square\square.\square\square \end{array}$$



Guided Practice



Determine the sum. Show your thinking.

5. $42.61 + 4.3 =$ _____

6. $20.77 + 1.03 =$ _____

7. $36.29 + 7.4 =$ _____

8. $19.58 + 6.41 =$ _____



Check



Determine the sum. Show your thinking.

1. $12.07 + 7.8 =$ _____

2. $42.19 + 3.45 =$ _____



Guided Practice

A Provide students with graph paper or lined paper oriented vertically that can be used to organize their decimals by place value.

Key Takeaway:

Say, “When using the standard algorithm to add decimals, it is important to add digits in the same place value. By lining up the numbers by place value, the decimal points will line up.”



Guided Practice



Determine the sum. Show your thinking. **Sample work shown.**

5. $42.61 + 4.3 = \underline{46.91}$

$$\begin{array}{r} 42.61 \\ + 4.30 \\ \hline 46.91 \end{array}$$

6. $20.77 + 1.03 = \underline{21.80}$

$$\begin{array}{r} 20.77 \\ + 1.03 \\ \hline 21.80 \end{array}$$

7. $36.29 + 74 = \underline{43.69}$

$$\begin{array}{r} 36.29 \\ + 74.40 \\ \hline 43.69 \end{array}$$

8. $19.58 + 6.41 = \underline{25.99}$

$$\begin{array}{r} 19.58 \\ + 6.41 \\ \hline 25.99 \end{array}$$



Check



Determine the sum. Show your thinking. **Sample work shown.**

1. $12.07 + 7.8 = \underline{19.87}$

$$\begin{array}{r} 12.07 \\ + 7.80 \\ \hline 19.87 \end{array}$$

2. $42.19 + 3.45 = \underline{45.64}$

$$\begin{array}{r} 42.19 \\ + 3.45 \\ \hline 45.64 \end{array}$$

Reflection

Ask:

- “How is adding decimals using the standard algorithm similar to adding whole numbers? How is it different?”
- “What makes sense? What is still confusing?”



Check: Recommended Next Steps

Almost there

If students need more support, consider drawing a place value chart to model organizing the digits in Problem 1 in the Check before solving. Then have students revisit Problem 2.

Got it!

If students need more practice, invite them to determine the sum for the following expressions:

- $4.51 + 12.9$
- $56.3 + 0.54$
- $0.03 + 12.18$

Adding and Subtracting Decimals

ML 5.12



Modeled Review

Name: Han

Determine the sum or difference. Show your thinking.

1. $2.4 + 4.76 = \underline{7.16}$

2. $9.7 - 6.45 = \underline{3.25}$

$$\begin{array}{r} 1 \\ 2.40 \\ + 4.76 \\ \hline 7.16 \end{array}$$

$$\begin{array}{r} 6 \ 10 \\ 9.\cancel{7}\cancel{0} \\ - 6.45 \\ \hline 3.25 \end{array}$$



Guided Practice



Determine the sum. Show your thinking.

1. $8.21 + 0.5 = \underline{\hspace{2cm}}$

2. $41.7 + 11.32 = \underline{\hspace{2cm}}$

$$\begin{array}{r} 8.21 \\ + 0.50 \\ \hline \square\square1 \end{array}$$

$$\begin{array}{r} 1 \\ 41.70 \\ + 11.32 \\ \hline \square\square\square2 \end{array}$$

3. $9.3 + 0.74 = \underline{\hspace{2cm}}$

4. $35.86 + 19.7 = \underline{\hspace{2cm}}$



Guided Practice



Determine the difference. Show your thinking.

5. $7.8 - 0.45 =$ _____

$$\begin{array}{r}
 \\
 7.80 \\
 - 0.45 \\
 \hline
 \\

 \end{array}$$

6. $31.6 - 14.08 =$ _____

$$\begin{array}{r}
 \\
 31.60 \\
 - 14.08 \\
 \hline
 \\

 \end{array}$$

7. $3.49 - 1.7 =$ _____

8. $13.2 - 6.52 =$ _____



Check



Determine the sum or difference. Show your thinking.

1. $17.5 + 3.41 =$ _____

2. $21.4 - 8.75 =$ _____

Goal

Add and subtract decimals to the hundredths place using the standard algorithm.

Standard

MA.5.NSO.2.3

Materials

graph or lined paper (optional)



Modeled Review

Point to Han's work and **ask**:

- "What did Han do to create decimal equivalence in both problems?"
- "How does adding zeros to the end of decimals affect the sum? Difference?"
- "How do you know when a zero needs to be added?"

Reinforce Han's thinking by saying, "It is important to line up digits by place when adding and subtracting decimals using the standard algorithm. Zeros can be recorded to represent an equivalent place, but are not always necessary."



Guided Practice

Focus students' attention on using place value understanding to determine the sum.

To scaffold their thinking, **ask**:

- "How would you use the standard algorithm to add if these were whole numbers?"
- "Will you need to compose? If so, where? How do you know?"
- "Will you need to extend both decimals to the same place value?"

Name _____

Adding and Subtracting Decimals

ML 5.12

Modeled Review



Name: Han

Determine the sum or difference. Show your thinking.

1. $2.4 + 4.76 = \underline{7.16}$

2. $9.7 - 6.45 = \underline{3.25}$

$$\begin{array}{r} 1 \\ 2.40 \\ + 4.76 \\ \hline 7.16 \end{array}$$

$$\begin{array}{r} 6\ 10 \\ 9.\cancel{7}0 \\ - 6.45 \\ \hline 3.25 \end{array}$$



Guided Practice



Determine the sum. Show your thinking.

Sample work shown for Problems 3 and 4.

1. $8.21 + 0.5 = \underline{8.71}$

2. $41.7 + 11.32 = \underline{53.02}$

$$\begin{array}{r} 8.21 \\ + 0.50 \\ \hline 8.71 \end{array}$$

$$\begin{array}{r} 41.70 \\ + 11.32 \\ \hline 53.02 \end{array}$$

3. $9.3 + 0.74 = \underline{10.04}$

4. $35.86 + 19.7 = \underline{55.56}$

$$\begin{array}{r} 1 \\ 9.30 \\ + 0.74 \\ \hline 10.04 \end{array}$$

$$\begin{array}{r} 1\ 1 \\ 35.86 \\ + 19.70 \\ \hline 55.56 \end{array}$$

Vocabulary

If needed, share the meaning of the terms with students.

sum: The value when two or more numbers are added.

difference: The amount you get when you subtract one number from another.

decompose: To break apart.

compose: To put together.

 **Guided Practice**

A Provide students with graph paper or lined paper oriented vertically that can be used to organize their decimals by place value.

ML/EL Model thinking aloud while solving each step of the algorithm and showing students where to record decomposed units.

Key Takeaway:

Say, “The only time you must extend both decimals to the same place value is when you are subtracting and the first number has fewer digits than the second number. In all other decimal addition and subtraction cases, extending to the same place value, by adding one or more zeros, is helpful but not necessary.”

 **Guided Practice**

Determine the difference. Show your thinking.

Sample work shown for Problems 7 and 8.

5. $7.8 - 0.45 = \underline{7.35}$

$$\begin{array}{r} 7.80 \\ - 0.45 \\ \hline 7.35 \end{array}$$

6. $31.6 - 14.08 = \underline{17.52}$

$$\begin{array}{r} 31.60 \\ - 14.08 \\ \hline 17.52 \end{array}$$

7. $3.49 - 1.7 = \underline{1.79}$

$$\begin{array}{r} 3.49 \\ - 1.70 \\ \hline 1.79 \end{array}$$

8. $13.2 - 6.52 = \underline{6.68}$

$$\begin{array}{r} 13.20 \\ - 6.52 \\ \hline 6.68 \end{array}$$

 **Check**

Determine the sum or difference. Show your thinking. Sample work shown.

1. $1.75 + 3.41 = \underline{20.91}$

$$\begin{array}{r} 1.750 \\ + 3.41 \\ \hline 20.91 \end{array}$$

2. $21.4 - 8.75 = \underline{12.65}$

$$\begin{array}{r} 21.40 \\ - 8.75 \\ \hline 12.65 \end{array}$$

Reflection

Ask:

- “When is it helpful to extend both decimals to the same place value when using the standard algorithm to add or subtract decimals?”
- “What is something you weren’t sure about at the start of the lesson but understand now?”

 **Check: Recommended Next Steps**

Almost there

If students need more support, consider using Mini-Lesson 5.10: *Adding Decimals* or Mini-Lesson 5.11: *Subtracting Decimals*.

Got it!

If students need more practice, invite them to determine the sum or difference for the following expressions:

- $12.47 - 7.9$
- $9.5 + 3.58$
- $23.48 + 6.3$

Multiplying Decimals Less Than 1

ML 5.16



Modeled Review

Name: Jack

Determine the product.

$$0.6 \times 0.6 = \underline{0.36}$$

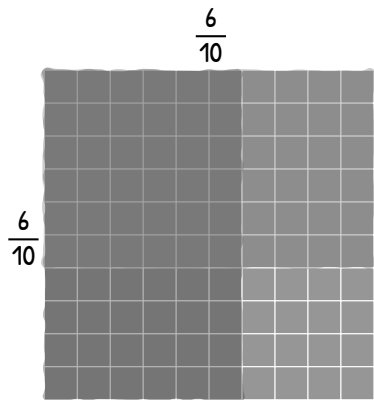

$$\frac{6}{10} \times \frac{6}{10} = \frac{36}{100} = 0.36$$



Guided Practice



Determine the product.

1. $0.3 \times 0.2 = \underline{\quad}$

$$\frac{\square}{10} \times \frac{\square}{10} = \frac{\square}{100} = \underline{\quad}$$

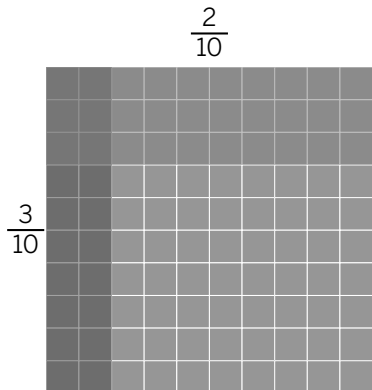

2. $0.4 \times 0.3 = \underline{\quad}$

$$\frac{\square}{10} \times \frac{\square}{10} = \underline{\quad}$$

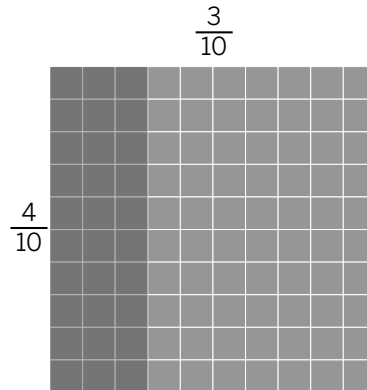



Guided Practice



Determine the product.

3. $0.2 \times 0.8 = \underline{\hspace{2cm}}$

4. $0.3 \times 0.6 = \underline{\hspace{2cm}}$

$_ \times _ = _ = \underline{\hspace{2cm}}$

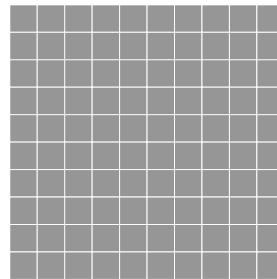
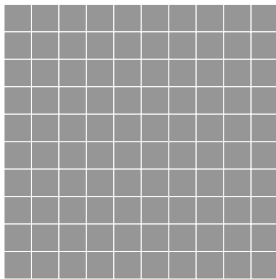

5. $0.5 \times 0.4 = \underline{\hspace{2cm}}$

6. $0.6 \times 0.4 = \underline{\hspace{2cm}}$

7. $0.7 \times 0.3 = \underline{\hspace{2cm}}$

8. $0.8 \times 0.4 = \underline{\hspace{2cm}}$



Check



Determine the product. Use a decimal grid if it is helpful.

1. $0.5 \times 0.8 = \underline{\hspace{2cm}}$

2. $0.3 \times 0.9 = \underline{\hspace{2cm}}$

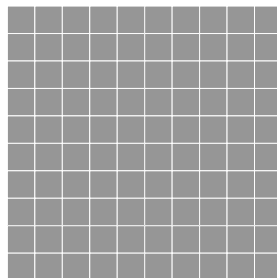
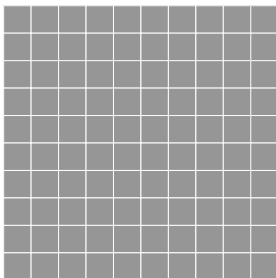

Goal

Multiply two decimals (tenths only) less than 1.

Standard

MA.5.NSO.2.5

Materials

coloring tools (optional)



Modeled Review

Point to Jack's work and **ask**:

- "How is multiplying fractions similar to multiplying decimals?"
- "Where do you see the numerators being multiplied in the decimal grid?"
- "Why is the product in the hundredths place?"
- "Why is the product less than the factors in the expression?"

Reinforce Jack's thinking by saying, "Just like when multiplying two fractions, when you multiply two decimals less than 1, you are determining part of a part. This means the product is less than both factors."



Guided Practice

Focus students' attention on converting the decimals to fractions then determining each product.

To scaffold their thinking, **ask**:

- "What are the factors in the expression? How can you write them as fractions?"
- "How could you represent each factor on the grid to help determine the product?"
- "What is the relationship between the numerators in the factors and the numerator in the product? Denominators?"

Name _____

Multiplying Decimals Less Than 1

ML 5.16

Modeled Review

Name: Jack

Determine the product.

$$0.6 \times 0.6 = \underline{0.36}$$

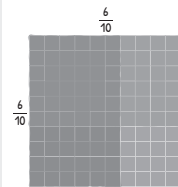

$$\frac{6}{10} \times \frac{6}{10} = \frac{36}{100} = 0.36$$

Guided Practice

Determine the product.

1. $0.3 \times 0.2 = \underline{0.06}$

$$\frac{3}{10} \times \frac{2}{10} = \frac{6}{100} = \underline{0.06}$$

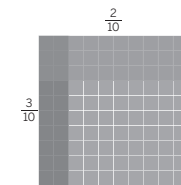

2. $0.4 \times 0.3 = \underline{0.12}$

$$\frac{4}{10} \times \frac{3}{10} = \frac{12}{100} = \underline{0.12}$$

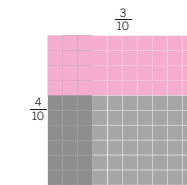

137

© Amplify Education, Inc and its licensors.

Vocabulary

If needed, share the meaning of the terms with students.

factor: A number that is multiplied by another number to determine the product.

product: The value when two or more numbers are multiplied.

expression: A mathematical statement with a minimum of two numbers and at least one math operation.



Guided Practice

A Provide students with coloring tools to represent the two decimals on the grid.

Key Takeaway:

Say, "You can use what you know about fraction multiplication, whole number facts, and place value to multiply two decimals less than 1."



Guided Practice



Determine the product. **Sample work shown.**

$$3. \quad 0.2 \times 0.8 = \underline{0.16}$$

$$\frac{2}{10} \times \frac{8}{10} = \frac{16}{100} = \underline{0.16}$$

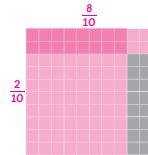

$$4. \quad 0.3 \times 0.6 = \underline{0.18}$$

$$\frac{3}{10} \times \frac{6}{10} = \frac{18}{100} = \underline{0.18}$$

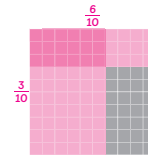

$$5. \quad 0.5 \times 0.4 = \underline{0.20}$$

$$\frac{5}{10} \times \frac{4}{10} = \frac{20}{100} = \underline{0.20}$$

$$6. \quad 0.6 \times 0.4 = \underline{0.24}$$

$$\frac{6}{10} \times \frac{4}{10} = \frac{24}{100} = \underline{0.24}$$

$$7. \quad 0.7 \times 0.3 = \underline{0.21}$$

$$\frac{7}{10} \times \frac{3}{10} = \frac{21}{100} = \underline{0.21}$$

$$8. \quad 0.8 \times 0.4 = \underline{0.32}$$

$$\frac{8}{10} \times \frac{4}{10} = \frac{32}{100} = \underline{0.32}$$



Check



Determine the product. Use a decimal grid if it is helpful. **Sample work shown.**

$$1. \quad 0.5 \times 0.8 = \underline{0.40}$$

$$\frac{5}{10} \times \frac{8}{10} = \frac{40}{100} = \underline{0.40}$$

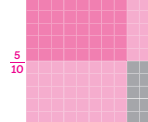

$$2. \quad 0.3 \times 0.9 = \underline{0.27}$$

$$\frac{3}{10} \times \frac{9}{10} = \frac{27}{100} = \underline{0.27}$$

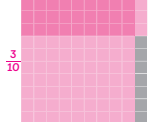

138

© Amplify Education, Inc. and its licensors.

Reflection

Ask:

- "What did you learn about the product of two decimals less than 1?"
- "Reflect on your learning today. What were you most proud of?"



Check: Recommended Next Steps

Almost there

If students need more support, consider using a think-aloud as you model converting the factors in the Check to fractions. Then represent the fractions on a grid as you reinforce how to determine the product using the grid.

Got it!

If students need more practice, invite them to determine the product for the following expressions:

- 0.9×0.4
- 0.2×0.5
- 0.5×0.7
- 0.8×0.3

Multiplying Two Decimals Greater than 1

ML 5.18



Modeled Review



Name: Priya

Determine the product. Show your thinking.

$14.6 \times 8.2 = \underline{119.72}$

	14	0.6
8	112	4.8
0.2	2.8	0.12

	1
112.00	
4.80	
2.80	
+ 0.12	
119.72	



Guided Practice



Determine the product. Show your thinking.

1. $10.5 \times 2.1 = \underline{\hspace{2cm}}$

	10	0.5
2	20	1
0.1	1	

2. $10.8 \times 4.3 = \underline{\hspace{2cm}}$

	10	0.8
4	40	3.2
0.3	3	



Guided Practice



Determine the product. Show your thinking.

3. $10.2 \times 5.6 =$ _____

	10	0.2
5		
0.6		

4. $11.5 \times 7.5 =$ _____

5. $12.7 \times 9.1 =$ _____

6. $14.3 \times 8.6 =$ _____



Check



Determine the product. Show your thinking.

$13.4 \times 8.5 =$ _____

Goal

Multiply two decimals using area diagrams when both decimals are greater than 1.

Standard

MA.5.NSO.2.5

Materials

highlighter or colored pencils (optional)



Modeled Review

Point to Priya's work and **ask**:

- "How did Priya decompose 14.6 and 8.2 to help her multiply?"
- "How did Priya use multiplication to find the area of each rectangle?"
- "Why was Priya's last step addition?"

Reinforce Priya's thinking by saying, "When multiplying two decimals greater than 1, you can decompose the factors by place value and represent your partial products with an area diagram."



To support students with making connections between the problem and area model, invite them to use highlighters or colored pencils to draw connections between the numbers and how they are represented in the area model.



Guided Practice

Focus students' attention on using the area model to calculate the product.

To scaffold their thinking, **say**:

- "Calculate the area of each missing part."
- "Add all the areas together."

Name _____

Multiplying Two Decimals Greater than 1

ML 5.18

Modeled Review

Name: Priya

Determine the product. Show your thinking.

$$14.6 \times 8.2 = \underline{119.72}$$

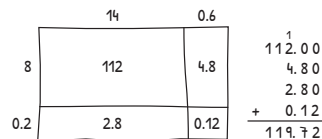

Guided Practice

Determine the product. Show your thinking. **Sample work shown.**

1. $10.5 \times 2.1 = \underline{22.05}$

2. $10.8 \times 4.3 = \underline{46.44}$

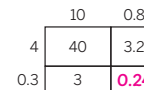
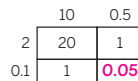

$$\begin{array}{r} 20.00 \\ 1.00 \\ 1.00 \\ + 0.05 \\ \hline 22.05 \end{array}$$

$$\begin{array}{r} 40.00 \\ 3.20 \\ 3.00 \\ + 0.24 \\ \hline 46.44 \end{array}$$

Vocabulary

If needed, share the meaning of the terms with students.

product: The value when two or more numbers are multiplied.

partial products: The value obtained when multiplying the parts of two numbers separately (which is then added to other partial products to arrive at the total product).



Guided Practice

A Model covering up the sections of the area model that are not being calculated to help students concentrate on one step of the process at a time.

Key Takeaway:

Say, "When multiplying two decimals greater than 1, you can decompose the factors and draw an area diagram to help you calculate the product."



Guided Practice

Determine the product. Show your thinking. **Sample work shown.**

3. $10.2 \times 5.6 = \underline{57.12}$

	10	0.2	
5	50	1	50.00 1.00 6.00 + 0.12 57.12
0.6	6	0.12	

4. $11.5 \times 7.5 = \underline{86.25}$

	11	0.5	
7	77	3.5	77.00 3.50 5.50 + 0.25 86.25
0.5	5.5	0.25	

5. $12.7 \times 9.1 = \underline{115.57}$

	12	0.7	
9	108	6.3	108.00 6.30 1.20 + 0.07 115.57
0.1	1.2	0.07	

6. $14.3 \times 8.6 = \underline{122.98}$

	14	0.3	
8	112	2.4	112.00 2.40 8.40 + 0.18 122.98
0.6	8.4	0.18	



Check

Determine the product. Show your thinking. **Sample work shown.**

$13.4 \times 8.5 = \underline{113.90}$

	13	0.4	
8	104	3.2	104.00 3.20 6.50 + 0.20 113.90
0.5	6.5	0.20	

Reflection

Ask:

- "What challenges did you run into when multiplying decimals with an area model, and how did you overcome them?"
- "How does what you learned today connect to your prior learning?"



Check: Recommended Next Steps

Almost there

If students need more support, consider modeling how to align the decimals and use zeros as placeholders when adding the four partial products to find the final product.

Got it!

If students need more practice, present them with the following problems and ask them to calculate the product using an area model.

- 13.8×3.2
- 14.5×4.4

Writing and Solving Equations

ML 6.04



Modeled Review

Name: Han

For Problems 1–3, use the equation $x + 2 = 10$.

- Write a situation that represents this equation. Explain what x represents in your situation.

Tristan spent \$10 on a box of tissues and medicine. The box of tissues cost \$2. The medicine cost x dollars.

$$x + 2 = 10$$

- Determine the solution to the equation.

$$x = 8$$

$$\begin{array}{r} x + 2 = 10 \\ - 2 \quad - 2 \\ \hline x = 8 \end{array}$$

$$x = 8$$

- Explain what the solution means in your situation.

The medicine cost \$8.



Guided Practice



For each situation, write the equation from the bank that best represents it.

$$x + 6 = 13$$

$$6x = 13$$

$$x + 2 = 7$$

$$2x = 7$$

$$x - 2 = 7$$

$$2x = 10$$

- Santiago spent \$7 on a cup of coffee and a croissant. The cup of coffee cost \$2. The croissant cost x dollars.

- Jada spent \$10 on two secondhand books. Each book cost x dollars.

- Diego spent \$13 on an herb plant and a pot. The plant cost \$6. The pot cost x dollars.



Guided Practice



4. Complete the table for each equation shown.

Equation	Situation	Solution	Solution's meaning
$x + 6 = 15$	Rebecca spent \$15 on a deck of cards and a phone charger. The deck of cards cost \$6. The phone charger cost x dollars.	$x = 9$	
$4x = 20$	Esteban spent \$20 on four greeting cards. Each greeting card cost x dollars.		
$x + 3 = 14$			



Check



For Problems 1–3, use the equation $x + 5 = 12$.

1. Write a situation that represents the equation. Explain what x represents in your situation.
2. Determine the solution to the equation.
3. Explain what the solution means in your situation.

Goal

Write descriptions for and solve one-step equations.

Standard

MA.6.AR.2.2



Modeled Review

Point to Han's work and **ask**:

- "How did Han write a situation to represent the equation?"
- "Why did Han subtract 2 from both sides of the equal sign?"
- "How did Han know the solution represented the cost of the medicine?"

Reinforce Han's thinking by saying, "An equation can be written as situations by focusing on the operation and its solution."

ML/EL To increase accessibility throughout the lesson, provide students with the opportunity to share their situations orally rather than in writing.



Guided Practice

Focus students' attention on representing each situation with an equation from the bank.

To scaffold their thinking, **ask**:

- "Which operation is represented by the situation?"
- "Is there anything about the situation that could help you decide which equation it matches?"
- "What does the solution mean according to the situation?"

Name _____

Writing and Solving Equations

ML 6.04



Modeled Review



Name: Han

For Problems 1–3, use the equation $x + 2 = 10$.

- Write a situation that represents this equation. Explain what x represents in your situation.
Tristan spent \$10 on a box of tissues and medicine. The box of tissues cost \$2. The medicine cost x dollars. $x + 2 = 10$
- Determine the solution to the equation. $-2 \quad -2$
 $x = 8$ $x = 8$
- Explain what the solution means in your situation.
The medicine cost \$8.



Guided Practice



For each situation, write the equation from the bank that best represents it.

$x + 6 = 13$	$6x = 13$	$x + 2 = 7$
$2x = 7$	$x - 2 = 7$	$2x = 10$

- Santiago spent \$7 on a cup of coffee and a croissant. The cup of coffee cost \$2. The croissant cost x dollars.
 $x + 2 = 7$
- Jada spent \$10 on two secondhand books. Each book cost x dollars.
 $2x = 10$
- Diego spent \$13 on an herb plant and a pot. The plant cost \$6. The pot cost x dollars.
 $x + 6 = 13$



Guided Practice

A To support students with their written responses, consider providing sentence frames, such as “Jack spent ___ on ___ packs of gum. Each pack cost ___ dollars.”

Key Takeaway:

Say, “Writing and solving equations can help us determine unknown information in a situation. A solution’s meaning depends on the situation the equation represents.”



Guided Practice

4. Complete the table for each equation shown. **Sample situation shown for Row 3.**

Equation	Situation	Solution	Solution's meaning
$x + 6 = 15$	Rebecca spent \$15 on a deck of cards and a phone charger. The deck of cards cost \$6. The phone charger cost x dollars.	$x = 9$	The phone charger cost \$9.
$4x = 20$	Esteban spent \$20 on four greeting cards. Each greeting card cost x dollars.	$x = 5$	Each greeting card cost \$5.
$x + 3 = 14$	Riya spent \$14 on a box of crayons and a pack of paint brushes. The box of crayons cost \$3. The pack of paint brushes cost x dollars.	$x = 11$	The pack of paint brushes cost \$11.



Check

For Problems 1–3, use the equation $x + 5 = 12$.
Sample responses shown for Problems 1 and 3.

- Write a situation that represents the equation. Explain what x represents in your situation.
Jack spent \$12 on a pair of sunglasses and a shirt. The sunglasses cost \$5. The shirt cost x dollars.
- Determine the solution to the equation.
 $x = 7$
- Explain what the solution means in your situation.
The shirt cost \$7.

146

© Amplify Education, Inc and its licensors.

Reflection

Ask:

- “What do you think is important to remember when writing equations to represent situations?”
- “Reflect on your learning today. What were you most proud of?”



Check: Recommended Next Steps

Almost there

If students need more support, consider providing them with a list of topics they can use when generating situations to represent the equations.

- Grocery store
- Concession stand at a game

Got it!

If students need more practice, present them with the following problems. Ask them to write a situation and solve. Then describe what the solution means in their situation.

- $x + 7 = 20$
- $6x = 42$

Ordering and Comparing Positive and Negative Numbers

ML 7.04



Modeled Review



Name: Adam

Order the numbers from *least* to *greatest*.

-3	3.1	-2.5	2.5	0.25
----	-----	------	-----	------

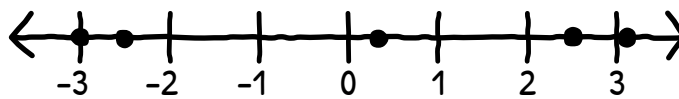

<u>-3</u>	<u>-2.5</u>	<u>0.25</u>	<u>2.5</u>	<u>3.1</u>
least				greatest



Guided Practice



Order each set of numbers from least to *greatest*. Use the number lines if they are helpful.

1.

0	-3.5	3	-1
---	------	---	----

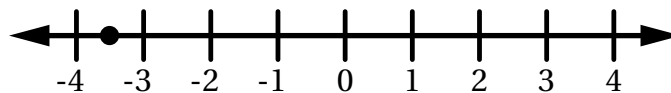

<u>-3.5</u>	_____	_____	_____
least			greatest

2.

4.5	-2	-4	0.25
-----	----	----	------

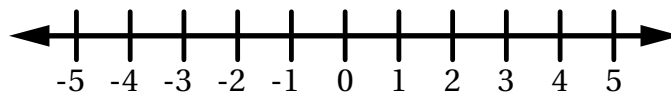

_____	_____	_____	_____
least			greatest



Guided Practice



Order each set of numbers from *least* to *greatest*.

3.

0.2	-2	3.5	3	1.25
-----	----	-----	---	------

_____ least _____ greatest

4.

$\frac{1}{2}$	3	$1\frac{1}{2}$	-2	1
---------------	---	----------------	----	---

_____ least _____ greatest

5.

2.5	2	-2.5	-0.5	-3
-----	---	------	------	----

_____ least _____ greatest

6.

$-3\frac{1}{2}$	$-\frac{1}{5}$	$2\frac{1}{2}$	-5	3
-----------------	----------------	----------------	----	---

_____ least _____ greatest



Check



Order the numbers from *least* to *greatest*.

$-\frac{1}{2}$	1	-3	4	$-4\frac{1}{2}$
----------------	---	----	---	-----------------

_____ least _____ greatest

Goal

Order and compare positive and negative numbers represented as fractions and decimals.

Standards

MA.6.NSO.1.1



Modeled Review

Point to Adam's work and **ask**:

- "How could Adam tell if one number was greater than or less than another number?"
- "How could Adam tell if two numbers were opposites?"
- "How was using a number line helpful?"

Reinforce Adam's thinking by saying, "Using a number line can help efficiently order and compare positive and negative numbers."



Guided Practice

Focus students' attention on ordering and comparing numbers using a number line.

To scaffold their thinking, **say**:

- "Find the smallest number and add it to the number line."
- "Then, look for the next smallest number and add it to the number line."
- "Continue this process until you have placed all of the numbers on the number line from least to the greatest."

Name _____

Ordering and Comparing Positive and Negative Numbers

ML 7.04

Modeled Review

Name: Adam

Order the numbers from *least* to *greatest*.



Guided Practice

Order each set of numbers from *least* to *greatest*. Use the number lines if they are helpful.

1. 0 -3.5 3 -1



-3.5 -1 0 3
least greatest

2. 4.5 -2 -4 0.25



-4 -2 0.25 4.5
least greatest

149

© Amplify Education, Inc and its licensors.

Vocabulary

If needed, share the meaning of the terms with students.

sign: The sign of a number (other than '0') is either positive or negative.

opposite: Two numbers that are the same distance from 0 and on different sides of the number line. For example, 4 and -4 are opposites.

rational number: All positive and negative numbers that can be written as fractions, including whole numbers, are called rational numbers.



Guided Practice

A Model crossing off the numbers in the list as they are ordered to ensure that all numbers have been included and none are overlooked.

ML/EL Guide processing by having students identify the decimal represented by each fraction before ordering the numbers from least to greatest.

Key Takeaway:

Say, “When ordering rational numbers, list them in the direction they appear on the number line: left to right for least to greatest.”



Guided Practice

Order each set of numbers from *least* to *greatest*.

3.	0.2	-2	3.5	3	1.25
	-2	0.2	1.25	3	3.5
	least		greatest		

4.	$\frac{1}{2}$	3	$1\frac{1}{2}$	-2	1
	-2	0.5	1	$1\frac{1}{2}$	3
	least		greatest		

5.	2.5	2	-2.5	-0.5	-3
	-3	-2.5	$-\frac{1}{2}$	2	2.5
	least		greatest		

6.	$-3\frac{1}{2}$	$-\frac{1}{5}$	$2\frac{1}{2}$	-5	3
	-5	-3.5	$-\frac{1}{5}$	2.5	3
	least		greatest		



Check

Order the numbers from *least* to *greatest*.

$-\frac{1}{2}$	1	-3	4	$-4\frac{1}{2}$
-4.5	-3	$-\frac{1}{2}$	1	4
least		greatest		

Reflection

Ask:

- “What steps should you take when ordering positive and negative numbers from least to greatest?”
- “What strategy was helpful today?”



Check: Recommended Next Steps

Almost there

If students need more support, consider having them revisit the problem in the Check. Then model drawing a number line and adding tick marks to support students with ordering the numbers.

Got it!

If students need more practice, present them with the following numbers and ask them to order these numbers from least to greatest.

-0.75	2	-5	3	-2.5
-------	---	----	---	------

Adding and Subtracting Positive and Negative Numbers

ML 7.08



Modeled Review



Name: Tristan

Evaluate each expression.

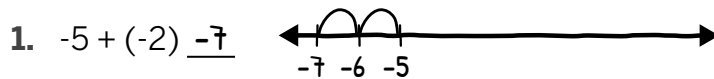

I need to start at -5, and move left 2 times to represent adding -2.



I need to start at -2, and move right 5 times.



Guided Practice



Evaluate each expression using a number line.

1. $-3 - 2 = \underline{\quad}$

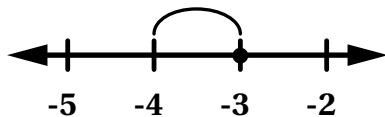

2. $-2 + 3 = \underline{\quad}$

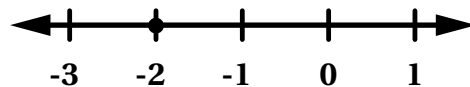

3. $1 - 3 = \underline{\quad}$

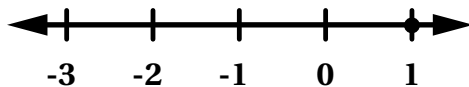

4. $-2 - (-1) = \underline{\quad}$

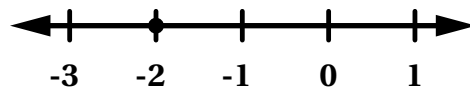



Guided Practice



5. Evaluate each expression.

Addition Expression	Subtraction Expression
$-4 + 1$ ____	$4 - 1$ ____
$2 + (-3)$ ____	$3 - (-2)$ ____
$-1 + 5$ ____	$-5 - 1$ ____
$-3 + -3$ ____	$-3 - (-3)$ ____
$-2 + 5$ ____	$5 - (-2)$ ____



Check



Evaluate each expression.

Addition Expression	Subtraction Expression
$-4 + (-2)$ ____	$-2 - (-4)$ ____

Goal

Calculate sums and differences of positive and negative numbers.

Standard

MA.6.NSO.4.1

Materials

number line (optional)



Modeled Review

Point to Tristan's work and ask:

- "How did Tristan use a number line to add integers? Subtract?"
- "Why is subtracting negative numbers equivalent to adding positive numbers?"

Reinforce Tristan's thinking by saying, "Number lines can be used to add and subtract integers."



Consider using a think aloud to reinforce that adding a negative number is equivalent to subtracting a positive number and subtracting a negative number is equivalent to adding a positive number.



Guided Practice

Focus students' attention on adding and subtracting integers.

To scaffold their thinking, ask:

- "What operation is in the expression?"
- "How can you use the number line to add or subtract integers?"

Name _____

Adding and Subtracting Positive and Negative Numbers

ML 7.08

Modeled Review

Name: Tristan

Evaluate each expression.

1. $-5 + (-2) = -7$



I need to start at -5, and move left 2 times to represent adding -2.

2. $-2 - (-5) = 3$

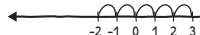

I need to start at -2, and move right 5 times.

Guided Practice

Evaluate each expression using a number line.

1. $-3 - 2 = -5$

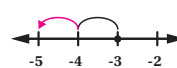

2. $-2 + 3 = 1$

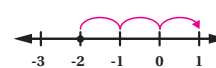

3. $1 - 3 = -2$

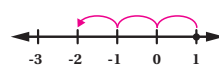

4. $-2 - (-1) = -1$

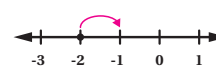

Vocabulary

If needed, share the meaning of the term with students.

integers: Whole numbers, their opposites, and 0.



Guided Practice

A Provide students with a number line to use as they evaluate each expression.

Key Takeaway:

Say, “Subtracting a value is equivalent to adding its opposite.”



Guided Practice

5. Evaluate each expression.

Addition Expression	Subtraction Expression
$-4 + 1$ <u>-3</u>	$4 - 1$ <u>3</u>
$2 + (-3)$ <u>-1</u>	$3 - (-2)$ <u>5</u>
$-1 + 5$ <u>4</u>	$-5 - 1$ <u>-6</u>
$-3 + -3$ <u>-6</u>	$-3 - (-3)$ <u>0</u>
$-2 + 5$ <u>3</u>	$5 - (-2)$ <u>7</u>



Check

Evaluate each expression.

Addition Expression	Subtraction Expression
$-4 + (-2)$ <u>-6</u>	$-2 - (-4)$ <u>2</u>

154

© Amplify Education, Inc and its licensors.

Reflection

Ask:

- “How does using a number line help add and subtract integers?”
- “What makes sense? What is still confusing?”



Check: Recommended Next Steps

Almost there

If students need more support, consider using the concepts of money to help make adding and subtracting integers less abstract. Positive numbers can represent having or receiving money. Negative numbers can represent situations involving expenses or debts.

Got it!

If students need more practice, have them evaluate the following expressions:

- $-6 + (-2)$
- $-2 - (-6)$
- $-7 + (-3)$
- $-3 - (-7)$

Solving Real-World Problems Involving Positive and Negative Numbers

ML 7.09



Modeled Review

Name: Santiago

Use the table to determine the change.

Date	Temperature in Kazan, Russia (°F)
December 20, 2019	-11
July 27, 2020	60

Positive change

What is the change in Kazan's temperature from December 20th to July 27th?

$$60 - (-11) = 60 + 11 = 71$$

71 degrees Fahrenheit

Since I am calculating the change, I need to find the difference between the final temperature and the initial temperature.



Guided Practice



Use the tables to determine if each temperature change in Fitzgerald, Canada is positive or negative.

1.

Date	Temperature (°F)
January 29, 2020	10
May 30, 2020	50

Positive Change or Negative Change

2.

Date	Temperature (°F)
June 24, 2019	60
February 9, 2020	-5

Positive Change or Negative Change

3.

Date	Temperature (°F)
December 19, 2019	-4
January 28, 2020	-8

Positive Change or Negative Change

4.

Date	Temperature (°F)
December 14, 2019	-2
July 8, 2020	70

Positive Change or Negative Change



Guided Practice



Use the tables to determine the change in temperature.

5.

Date	Temperature in Siberia, Russia (°F)
July 24, 2019	50
February 11, 2020	-10

What is the change in Siberia's temperature from July 24th to February 11th?

6.

Date	Temperature in Fairbanks, Alaska (°F)
January 2, 2020	-5
September 25, 2020	45

What is the change in Fairbanks's temperature from January 2nd to September 25th?

7.

Date	Temperature in Harbin, China (°F)
December 13, 2019	-8
August 20, 2020	68

What is the change in Harbin's temperature from December 13th to August 20th?



Check



Use the table to determine the temperature change.

Date	Temperature in Prospect Creek, Alaska (°F)
February 26, 2020	-7
August 9, 2020	63

What is the change in Prospect Creek's temperature from February 26th to August 9th?

Goal

Add and subtract positive and negative numbers to solve problems involving real-world situations.

Standard

MA.6.NSO.4.1

Materials

highlighter (optional), number line (optional)



Modeled Review

Point to Santiago's work and ask:

- "Why does Santiago say it is a positive change?"
- "Why does Santiago subtract the initial from the final temperature?"
- "How does knowing the table reflects a positive change help you check the calculated answer?"

Reinforce Santiago's thinking by saying, "Use your knowledge of adding and subtracting positive and negative numbers to solve real-world situations."



Guided Practice

Focus students' attention on determining if each temperature change is positive or negative.

To scaffold their thinking, **ask**:

- "What's the initial temperature?"
- "What's the final temperature?"
- "Is that change a positive (getting warmer) or negative (getting colder) change?"

Name _____

Solving Real-World Problems Involving Positive and Negative Numbers ML 7.09

Modeled Review

Name: Santiago

Use the table to determine the change.

Date	Temperature in Kazan, Russia (°F)
December 20, 2019	-11
July 27, 2020	60

Positive change

What is the change in Kazan's temperature from December 20th to July 27th?

$$60 - (-11) = 60 + 11 = 71$$

71 degrees Fahrenheit

Since I am calculating the change, I need to find the difference between the final temperature and the initial temperature.

Guided Practice

Use the tables to determine if each temperature change in Fitzgerald, Canada is positive or negative.

1.

Date	Temperature (°F)
January 29, 2020	10
May 30, 2020	50

Positive Change or Negative Change

2.

Date	Temperature (°F)
June 24, 2019	60
February 9, 2020	-5

Positive Change or Negative Change

3.

Date	Temperature (°F)
December 19, 2019	-4
January 28, 2020	-8

Positive Change or Negative Change

4.

Date	Temperature (°F)
December 14, 2019	-2
July 8, 2020	70

Positive Change or Negative Change

Vocabulary

If needed, share the meaning of the term with students.

integers: Whole numbers and their opposites.



Guided Practice

A Model color coding positive and negative numbers with a highlighter for students to understand whether it will be a positive or negative change.

ML/EL Consider modeling, or inviting a student to model, annotating the problem to make sense of it, such as labeling the first temperature as the initial and second as the final.

Key Takeaway:

Say, "Adding and subtracting positive and negative values help to solve problems involving real-world situations."



Guided Practice

Use the tables to determine the change in temperature.

5.

Date	Temperature in Siberia, Russia (°F)
July 24, 2019	50
February 11, 2020	-10

What is the change in Siberia's temperature from July 24th to February 11th?
-60 degrees Fahrenheit

6.

Date	Temperature in Fairbanks, Alaska (°F)
January 2, 2020	-5
September 25, 2020	45

What is the change in Fairbanks's temperature from January 2nd to September 25th?
50 degrees Fahrenheit

7.

Date	Temperature in Harbin, China (°F)
December 13, 2019	-8
August 20, 2020	68

What is the change in Harbin's temperature from December 13th to August 20th?
76 degrees Fahrenheit



Check

Use the table to determine the temperature change.

Date	Temperature in Prospect Creek, Alaska (°F)
February 26, 2020	-7
August 9, 2020	63

What is the change in Prospect Creek's temperature from February 26th to August 9th? **70 degrees Fahrenheit**

Reflection

Ask:

- "What new questions do you have about adding and subtracting positive and negative numbers?"
- "How does what you learned today connect to your prior learning?"



Check: Recommended Next Steps

Almost there

If students need more support, consider orienting a number line vertically so they can understand whether a positive or negative change is occurring in the context of temperature, and then check it against their calculated solution.

Got it!

If students need more practice, present them with the following table and ask them to determine the change in Fairbanks' weather from February 29th to March 28th.

Month	Temperature in Fairbanks, Alaska (°F)
February 29, 2020	-33
March 28, 2020	-4



Extensions

Unit 1

Extensions

Name: Date: Period:

Student Choice

Start with any problem. Remember to show or explain your thinking.

1

Remove eight toothpicks from the given design to create two squares.

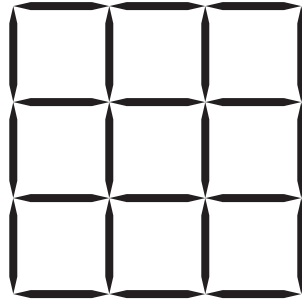
**2**

Eight identical rectangles form a larger rectangle, as shown in the figure. Suppose you know that the length and width of the smaller rectangles are whole numbers, and the area of the larger rectangle is 480 square feet. Determine the perimeter of the larger rectangle.

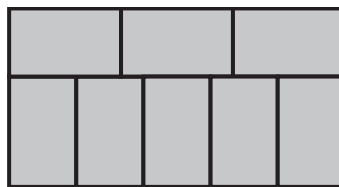

Name: Date: Period:

3

Tetrominoes are shapes made up of four squares. These are the tiles of the famous game Tetris.

All tetrominoes are examples of replicating tiles (*rep-tiles*), shapes that can tile an enlargement of themselves.

For example, the I tetromino can tile differently scaled copies of itself.

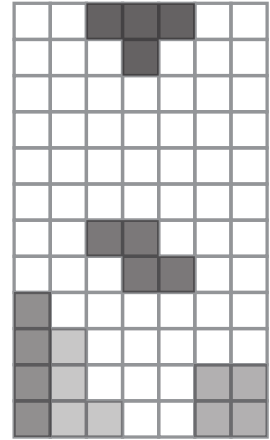
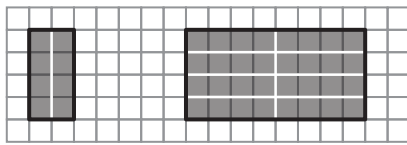

- a Use the L shape tetromino to tile each of these scaled copies of itself and determine the scale factors.

× 1 × _____ × _____ × _____

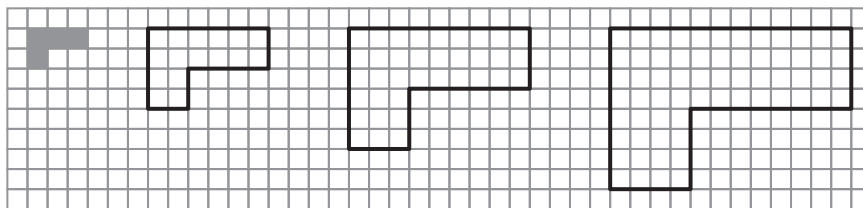

- b Do you think any enlargement of the L tetromino can be tiled using the L tetromino?

- c Is it possible to use the T tetromino to fill any scaled copies of itself?

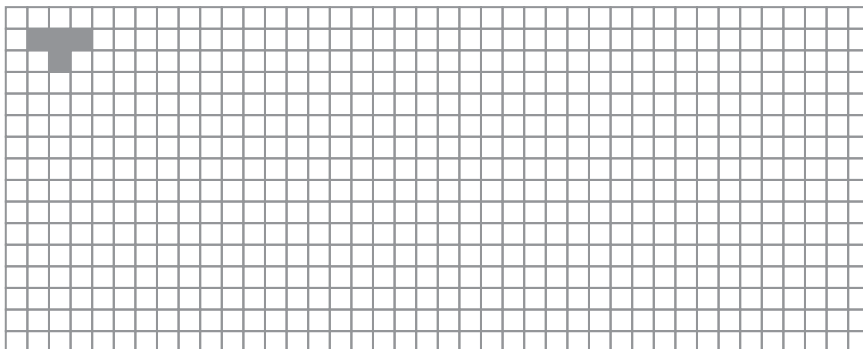

Assign problems to students who want to extend their thinking.

Problems 1, 2, and 3 can be solved in any order. If time allows, consider sharing Problem 3 with all students.

Materials

- toothpicks (optional) **(Problem 1)**
- graph paper (optional) **(Problem 3)**

Problem 1

Students will extend their understanding of objects that are scaled copies of one another by solving the toothpick puzzle.

Provide students with the following hint if additional scaffolding is needed.

- **Hint:** You can use toothpicks to help you visualize the puzzle better.

Responses vary.

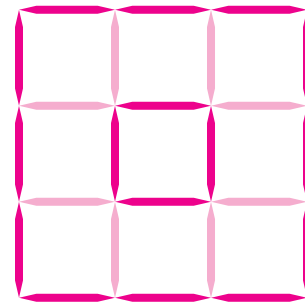
**Problem 2**

Students will extend their understanding of identical shapes, ratios, and both perimeter and area calculations by solving this problem.

Provide students with the following hint if additional scaffolding is needed.

- **Hint:** If you were to redraw this shape on grid paper, how would you arrange the length and width of the small rectangles so that three times the length would be the same as five times the width?

92 feet. Explanations vary.

I labeled the width of the small rectangle a and the length b . The top and bottom of the rectangle are the same length, so I know that $3b = 5a$.

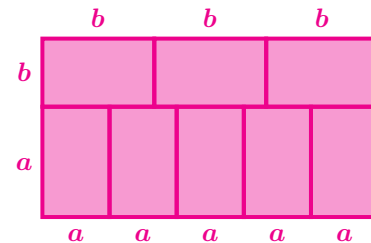

8 rectangles fit in the area of the larger rectangle, so the area of each small rectangle is $480 \div 8 = 60$ sq. feet. I checked all the pairs of numbers with a product of 60, and the only pair that makes $3b = 5a$ is $a = 6$ and $b = 10$. So, the perimeter of the larger rectangle is $2 \cdot 5 \cdot 6 + 2 \cdot (10 + 6) = 92$ feet.

Continued next page ...

Problem 3

Students will extend their understanding of how scaling affects lengths, angles, and areas in scaled copies by working with tetrominoes.

Provide students with the following hint if additional scaffolding is needed.

- **Hint:** Which polygons can always create scaled copies of themselves? How can you use the L tetromino to create one of those polygons?

a. Responses vary.

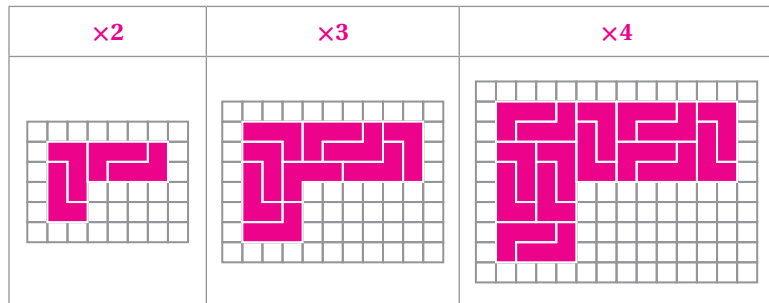

The number of tetrominoes needed in the enlargements is always a square of the scale factor.

b. Any integer-sized enlargement of the L tetromino can be tiled using small copies of the L tetromino. For example:

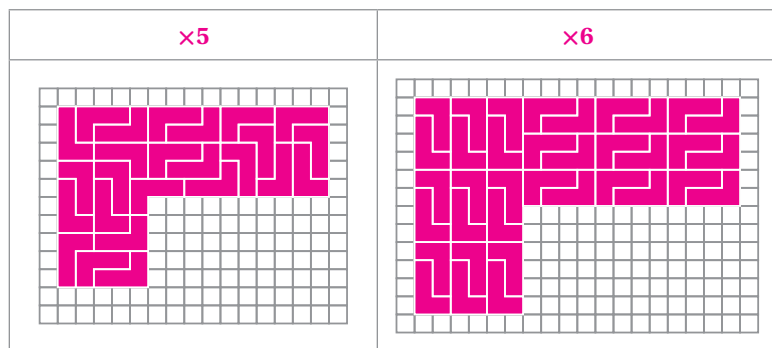

c. Some, but not all, enlargements of the T tetromino can be rep-tiled. For example, I cannot create a T tetromino rep-tile that is 2 times larger, but I can create the rep-tile that is 4 times larger.

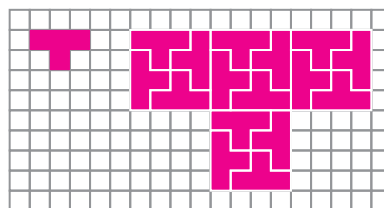

Name: Date: Period:

Student Choice

Start with any problem. Remember to show or explain your thinking.

1

According to legend, the city of Delos in ancient Greece was once faced with a terrible plague.

An oracle told them that the plague would go away if they built a new temple that was exactly twice the volume of the existing one.

Delians doubled the lengths of the edges of the temple, but the plague did not stop. What do you think went wrong?



2

Here is a *spidron*. It's a continuous geometric figure made entirely from scaled copies of itself.

This spidron is a replica of the first spidron created by Dániel Erdély in 1979. It consists of equilateral triangles and isosceles triangles pasted together to form right triangles.

Use the grid to create your own spidron design by choosing a shape and a scale factor.

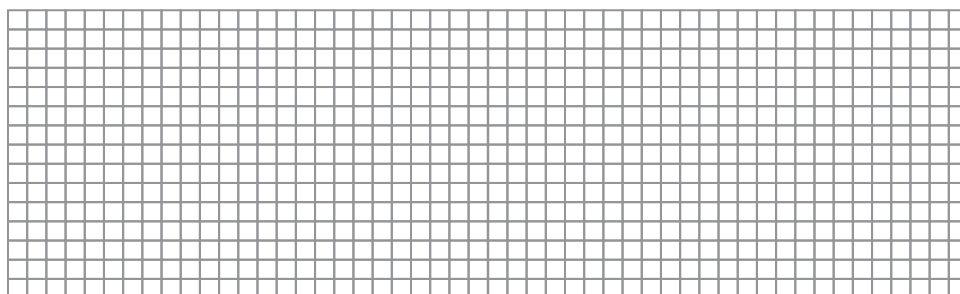
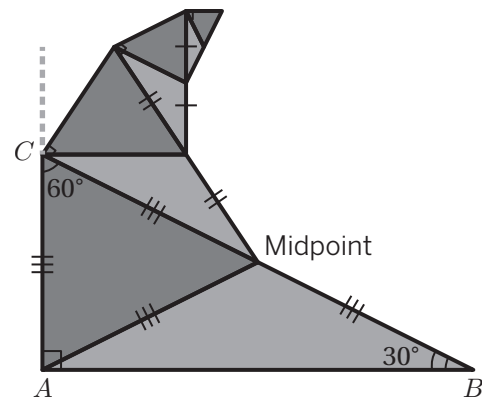

Name: Date: Period:

3

These tables show the distance between the Sun and the eight planets in our solar system.

Planet	Average Distance From Sun (millions of miles)
Mercury	35
Venus	67
Earth	93
Mars	142

Planet	Average Distance From Sun (millions of miles)
Jupiter	484
Saturn	887
Uranus	1,784
Neptune	2,795

- a** If you wanted to create a scale model of the solar system that could fit somewhere in your school, what scale would you use?
- b** The diameter of Earth is approximately 8,000 miles. What would the diameter of Earth be in your scale model?

Assign problems to students who want to extend their thinking.

Problems 1, 2, and 3 can be solved in any order. If time allows, consider sharing Problems 1 and 2 with all students.

Materials

- graph or isometric grid paper (**Problem 2**)
- compasses, protractors, and straight edges (**Problem 2**)

Problem 1

Students will extend their understanding of scaled copies by analyzing scale drawings of a real-life object.

Provide students with the following hint if additional scaffolding is needed.

- **Hint:** How does the volume of a cube change when you double each side length?

Explanations vary.

When the Delians doubled each side length of the temple, the volume became 8 times the original volume of the temple, but the oracle only asked to double the volume. The Delians should have scaled each side by a factor of about 1.25.

Problem 2

Students will extend their understanding of scaled copies by designing scale drawings of a figure they choose.

Provide students with the following hint if additional scaffolding is needed.

- **Hint:** Think of the spidron-designing process like continuously folding a piece of paper. What do you think is the easiest scale factor to work with?

Designs vary. Sample designs shown.

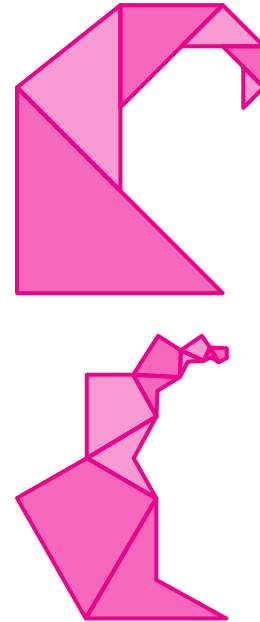

Continued next page ...

Problem 3

Students will extend their understanding of scale models by determining and applying a scale of their choosing in the given scenario.

Provide students with the following hints if additional scaffolding is needed.

- **Hint 1:** What are the largest numbers you need to consider when creating a model?
- **Hint 2:** Does your model assume the smallest possible version of our solar system (all planets between Neptune and the Sun) or the largest (Neptune on one side and Uranus on the opposite side)?

a. *Responses vary.*

The gym has a space of about 100 feet by 100 feet. The largest distance I need to represent is between the Sun and Neptune, which is about 3 billion miles. So, if 1 foot represents about 30 million miles, the solar system could fit in the gym with all planets between Neptune and the Sun.

b. *Responses vary.*

In my model, 30 million miles is equivalent to 1 foot. I can divide 8,000 by 30 million to find the scaled diameter of Earth in my model:

$$\frac{8000}{30000000} = \frac{1}{3750} \approx 0.000267 \text{ feet,}$$

or about 0.0032 inches.

Unit 2

Extensions

Name: Date: Period:

Student Choice

Start with any problem. Remember to show or explain your thinking.

1

Farah used a blue marker to divide a plank of wood into 5 equal parts. Raven then used a red marker to divide the same plank of wood into 7 equal parts.

- a** Name the colors on the plank from left to right. Draw a picture if it helps with your thinking.

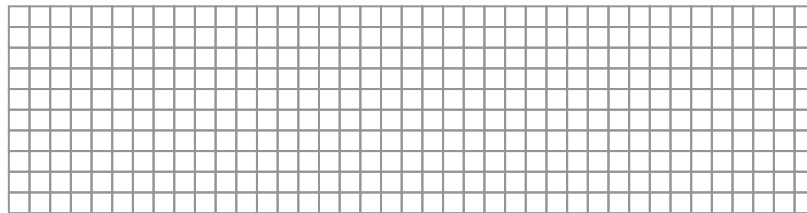

- b** If the plank is cut at each marking, determine the lengths of the shortest and longest pieces.

2

If $a : b = 9 : 4$ and $b : c = 5 : 3$, determine the proportion $(a - b) : (b - c)$.

Name: Date: Period:

3

Two thirds of Pablo's coins are nickels, one fourth are dimes, and the rest are quarters. If the total value of the coins is \$6.65, how many of Pablo's coins are nickels? Dimes? Quarters?

Assign problems to students who want to extend their thinking.

Problems 1–3 can be solved in any order. If time allows, consider sharing Problems 1 and 2 with all students.

Materials

- coloring tools (**Problem 1**)

Problem 1

Students will extend their understanding of

proportions by dividing the length of a plank into different pieces.

Provide students with the following hints if additional scaffolding is needed.

- Hint:** Think about a possible length for the plank where you could easily divide by both 5 and 7.

a. Red, blue, red, blue, red, red, blue, red, blue, red.

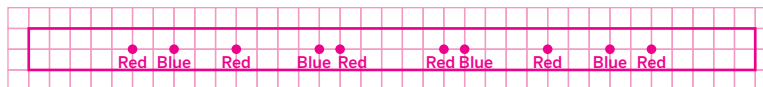

b. The shortest length would be $\frac{1}{35}$ of the total length of the plank, and the longest length would be $\frac{1}{7}$ of the total length.

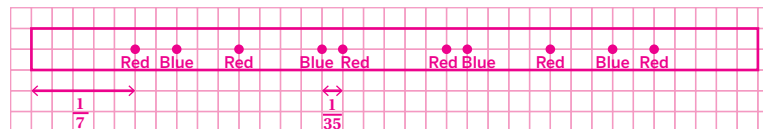

Problem 2

Students will extend their understanding of writing equations to describe proportional thinking in scenarios by solving proportional problems with variables.

Provide students with the following hints if additional scaffolding is needed.

- Hint:** What is the common value in both proportions? How can having a common value help us write a proportion that includes all the variables?

25 : 8. Explanations vary. In both proportions, b is the common value. I created a table to find where the b value is the same for both proportions.

a	b
9	4
45	20

b	c
5	3
20	12

If I write the proportion $a : b : c$ as $45 : 20 : 12$, then I can subtract to find $(a - b) : (b - c) = 25 : 8$.

Continued next page ...

Problem 3

Students will extend their understanding of writing equations to describe proportional thinking in scenarios by connecting fractions and proportions.

Provide students with the following hints if additional scaffolding is needed.

- **Hint:** If there were 12 coins, how many of them would be nickels? Dimes? Quarters? What would be the total amount then?

56 nickels, 21 dimes, 7 quarters.

Explanations vary. To determine the fraction of Pablo's coins that are quarters, I first added $\frac{2}{3} + \frac{1}{4} = \frac{8}{12} + \frac{3}{12} = \frac{11}{12}$, which tells me that only $\frac{1}{12}$ of Pablo's coins are quarters.

If there were 12 coins, there would be 8 nickels, 3 dimes, and 1 quarter. That makes a total of 95 cents. 95 cents is $\frac{1}{7}$ of the actual amount \$6.65, so I can multiply all the numbers by 7 to find out how many of each coin Pablo has.

Name: Date: Period:

Student Choice Start with any problem. Remember to show or explain your thinking.**1**

The closest planet outside of our solar system orbits the star Proxima Centauri, which is 1.3 parsecs from Earth.

A *parsec* is about 3.26 light years.

A *light year* is the distance light travels in one year.

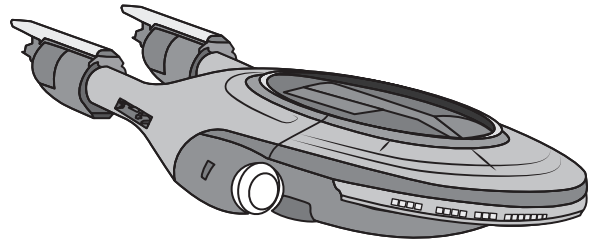

- a How long does it take light from Proxima Centauri to reach Earth?

- b How long would a voyage to Proxima Centauri take if a spaceship traveled at 90% the speed of light?

2

The International Space Station (ISS) is orbiting the Earth. The ISS is traveling in its orbit at a speed of 8 kilometers per second.

- a What information do you need to determine how long it takes the ISS to orbit Earth?

- b About how many hours does it take for the ISS to orbit Earth?

Name: Date: Period:

3

A train traveling at 30 miles per hour reaches a tunnel that is 9 times as long as the train. The train takes 2 minutes to completely clear the tunnel. How long is the train?

Assign problems to students who want to extend their thinking.

Problems can be solved in any order. Assign Problem 3 to students who have solved Problem 1. If time allows, consider sharing Problems 1 and 2 with all students.

Problem 1

Students will extend their understanding of speed and equations by extending their thinking to the speed of light.

- a. About 4.24 years, because $1.3 \cdot 3.26 \approx 4.24$.
- b. About 4.71 years, because $\frac{4.24}{0.9} \approx 4.71$.

Problem 2

Students will extend their understanding of equivalent ratios by determining how long it will take the International Space Station to orbit the Earth.

Provide students with the following hint if additional scaffolding is needed for part a, or if students request this information for part b.

- **Hint:** Earth's circumference is about 40,000 km.

- a. *Responses and explanations vary.* Since the ISS is orbiting around the Earth, I need to know the Earth's circumference.
- b. *Responses and explanations vary.* About 1.5 hours. Earth's circumference is about 40,000 kilometers. The orbit of the ISS is longer than this, but not a lot longer. The orbit will take a little more than $40000 \div 8 = 5000$ seconds. I can convert to minutes by dividing $5000 \div 60 \approx 83.3$. Because the orbit of the ISS has a slightly larger circumference, it will probably take closer to 90 minutes, which is 1.5 hours.

Continued next page ...

Problem 3

Students will extend their understanding of proportional relationships involving speed by using ratios and equations to determine an unknown distance.

Provide students with the following hint if additional scaffolding is needed.

- **Hint:** What is the distance to completely clear the tunnel if the length of the train is x ?

0.1 miles. *Explanations vary.* If the length of the train is x , then the distance to completely clear the tunnel is $10x$.

I need to convert 30 miles per hour into miles per minute, so I used a table to determine that the speed is equivalent to 0.5 miles per minute.

Miles	Minutes
30	60
0.5	1

Then I used the equation $d = rt$ to determine the length of the train x :

$$d = rt$$

$$10x = 0.5 \cdot 2$$

$$10x = 1$$

$$x = 0.1$$

Name: Date: Period:

Student Choice

Start with any problem. Remember to show or explain your thinking.

1

Dhruv, who is right-handed, and Maneli, who is left-handed, are in the same class.

Dhruv has twice as many right-handed classmates as left-handed classmates, not including himself.

Maneli has three times as many right-handed classmates as left-handed classmates, not including herself.

How many left-handed students are in the class?

Name: Date: Period:

2

An old man wanted to leave his 17 camels to his 3 sons, to be divided such that:

- The eldest son should inherit $\frac{1}{2}$ of the old man's property.
- The middle son should inherit $\frac{1}{3}$ of the old man's property.
- The youngest son should inherit $\frac{1}{9}$ of the old man's property.

Because 17 is not evenly divisible by 2, 3, and 9, he asked for help from an oracle about how to do this. The oracle told him that she can give him a camel, for a total of 18.

She said: *Your eldest son should get $18 \cdot \frac{1}{2} = 9$ camels, your middle son should get $18 \cdot \frac{1}{3} = 6$ camels, and your youngest should get $18 \cdot \frac{1}{9} = 2$ camels. That's a total of 17 camels, and you can give my camel back afterward.*

How do you think the oracle thought of this trick? What advice could she have given the old man at the beginning?

Assign problems to students who want to extend their thinking.

Problems 1 and 2 can be solved in any order. If time allows, consider sharing Problems 1 and 2 with all students.

Problem 1

Students will extend their understanding of comparing ratio relationships by determining the unknown when given two different perspectives.

Provide students with the following hints if additional scaffolding is needed.

- **Hint 1:** You can define two variables, R and L , to represent the total number of right- and left-handed students in the class. How can you describe Dhruv and Maneli's perspectives with a table of equivalent ratios using these variables?
- **Hint 2:** Once you have ratios for each student's perspective, you can make a second table that includes each student.
- **Hint 3:** How can you pick values of R and L so that both Dhruv and Maneli's perspectives are correct?

4 left-handed students. *Explanations vary.*

Because they are in the same class, Dhruv and Maneli's perspectives must be true at the same time. I made a table to test different values of R and L to see when both of their perspectives are true.

Dhruv's perspective	Right to Left ratio is 2 : 1	R	2	4	6	8
		L	1	2	3	4
		Including Dhruv among the right-handed students, the actual numbers are:				
Maneli's perspective	Right to Left ratio is 3 : 1	$R + 1$	3	5	7	9
		L	1	2	3	4
		Including Maneli among the left-handed students, the actual numbers are:				
		R	3	6	9	12
		L	1	2	3	4
		R	3	6	9	12
		$L + 1$	2	3	4	5

Problem 2

Students will extend their understanding of ratio relationships by solving the 17-camels puzzle.

Provide students with the following hint if additional scaffolding is needed.

- **Hint:** Think about the closest number of camels that can be divided in a ratio of $\frac{1}{2}$, $\frac{1}{3}$, and $\frac{1}{9}$.

Explanations vary. $\frac{1}{2} + \frac{1}{3} + \frac{1}{9} = \frac{17}{18}$, which is not equal to 1.

The oracle could have told the old man that the fractions were not set up correctly to divide all the camels among the sons at the beginning. Using these fractions the old man can share only the $\frac{17}{18}$ of his camels, not all of it.

Using Proportional Relationships

Name: Date: Period:

Student Choice

Start with any problem. Remember to show or explain your thinking.

1

Here is a different version of the famous chicken-and-the-egg problem, which is said to be written by Fibonacci.

If a chicken and a half can lay an egg and a half in a day and a half, how many eggs can three chickens lay in three days?

2

30 people planted 1,000 trees in 9 days. How many days would it take 36 people to plant 4,400 trees?

3

The ratio of 7th graders to 8th graders in a school band was 3 : 4 in the first quarter of a football game.

In the second quarter, three 7th graders joined the band and five 8th graders left.

As a result, the ratio of 7th graders to 8th graders became 6 : 5.

How many members did the band have originally?

Using Proportional Relationships

Assign problems to students who want to extend their thinking.

Problems 1 and 3 can be solved in any order. Assign Problem 2 to students who have solved Problem 1. If time allows, consider sharing Problem 3 with all students.

Problem 1

Students will extend their understanding of proportion by solving the chicken-and-the-egg puzzle with three variables.

Provide students with the following hints if additional scaffolding is needed.

- **Hint 1:** Since there are three values in this relationship, consider any two of them first, then consider how the third value relates to them.
- **Hint 2:** How long does it take for 3 chickens to lay 3 eggs?

6 eggs. *Explanations vary.*

If a chicken and a half can lay an egg and a half in a day and a half, then 3 chickens can lay 3 eggs in a day and a half. In three days, 3 chickens can lay 6 eggs.

Problem 2

Students will extend their understanding of proportion by solving the problem with three variables.

Provide students with the following hints if additional scaffolding is needed.

- **Hint 1:** Since there are three values in this relationship, consider any two of them first, then consider how the third value relates to them.
- **Hint 2:** How many trees can 36 people plant in 9 days?

33 days. *Explanations vary.*

Because $36 \div 30 = 1.2$, I know that 36 people can plant $1000 \cdot 1.2 = 1200$ trees in 9 days.

Because $4400 \div 1200 \approx 3.67$, I know that it will take $9 \cdot 3.67 \approx 33$ days for 36 people to plant 4,400 trees.

Problem 3

Students will extend their understanding of solving problems about proportional relationships by determining the original amount when given related ratios.

Provide students with the following hint if additional scaffolding is needed.

- **Hint:** How can equivalent ratios help you determine the correct number of students?

35 students. *Explanations vary.*

I used equivalent fractions to determine the pairs with the correct differences between the numerators and denominators.

$$\frac{3}{4} = \frac{6}{8} = \frac{9}{12} = \frac{12}{16} = \frac{15}{20} = \frac{18}{24}$$

$$\frac{6}{5} = \frac{12}{10} = \frac{18}{15} = \frac{24}{20}$$

This means the band originally started with 15 seventh graders and 20 eighth graders.

Unit 3

Extensions

Name: Date: Period:

Student Choice

Start with any problem. Remember to show or explain your thinking.

1

Explain how to determine the center of a paper circle without a ruler or a compass.

2

Consider the photos of a spring toy. If you could stretch out the spring completely straight, how long would it be?

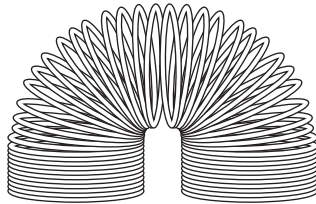
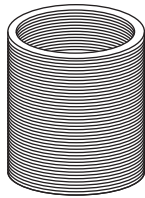

9.5 cm

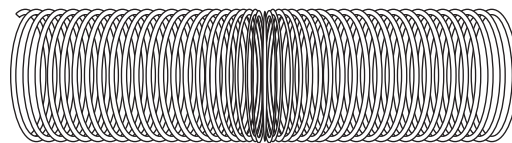
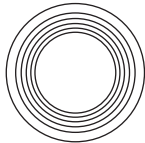

Name: Date: Period:

3

The shaded region is bound by two arcs, or parts of a circle, with the same radius of 7 centimeters. Determine the perimeter of the shaded region.

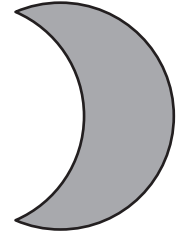
**4**

The circumference of Earth is approximately 40,000 kilometers. Imagine you wrapped a circle of wire around the planet that is only 10 meters longer than its circumference. Could a flea, a mouse, or even a person fit under it?

Assign problems to students who want to extend their thinking.

Problems can be solved in any order. If time allows, consider sharing Problems 1 and 3 with all students.

Problem 1

Students will extend their understanding of circles by explaining a way to determine the center of a circle without a ruler or compass.

Provide students with the following hint if additional scaffolding is needed.

- **Hint:** How can folding the paper help you determine the center?

Explanations vary. If I fold the paper circle in half, and then fold it in half again, I would be able to see the center of the circle.



Problem 2

Students will extend their understanding of circumference by calculating the length of a circular spring toy.

Provide students with the following hint if additional scaffolding is needed.

- **Hint:** How many loops can you count? How can the number of loops help you estimate the total length?

The length is about 12.5 meters or 1,253 centimeters. Explanations vary. I can compute the approximate length if I know the diameter of the circle and the number of loops. The diameter of the toy is about 9.5 centimeters, and I counted 42 loops.
 $9.5 \cdot \pi \cdot 42 \approx 1252.8$.

Continued next page ...

Problem 3

Students will extend their understanding of circumference by determining the perimeter of a circular shape.

Provide students with the following hint if additional scaffolding is needed.

- **Hint:** Complete the outer arc of the region to a full circle. What do you notice?

14π or about 44 centimeters.
Explanations vary. The inner arc can be repositioned to create a full circle with the outer arc since both arcs are part of a circle with the same radius.

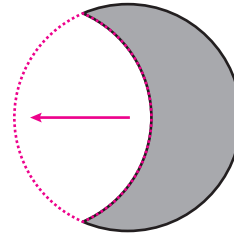

The perimeter of the shaded region is equivalent to the circumference of a circle with a radius of 7.
 $C = 2\pi \cdot 7 = 14\pi \approx 43.98.$

Problem 4

Students will extend their understanding of π by considering how changing the circumference changes the diameter.

Provide students with the following hint if additional scaffolding is needed.

- **Hint:** Determine how the circumference of a circle changes with each meter added to its diameter.

Yes. Explanations vary.
A flea, mouse, or person would be able to fit underneath it.

Each meter added to the diameter of a circle adds about 3.1 meters to the circumference of the circle.

So if the circumference of Earth is increased by 10 meters, this means that a little more than 3 meters have been added to the diameter. So there would be about 1.5 meters of distance between the wire and Earth, making it easy for a flea, mouse, or person to go under the wire.

Name: Date: Period:

Student Choice Start with any problem. Remember to show or explain your thinking

1

a What fraction of the whole circle is unshaded?

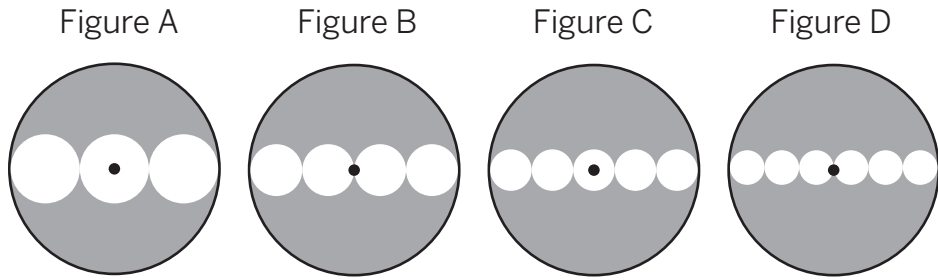

b What fraction of the next figure circle will be unshaded?

Name: Date: Period:

2

a Determine the area of each figure. What do you notice?

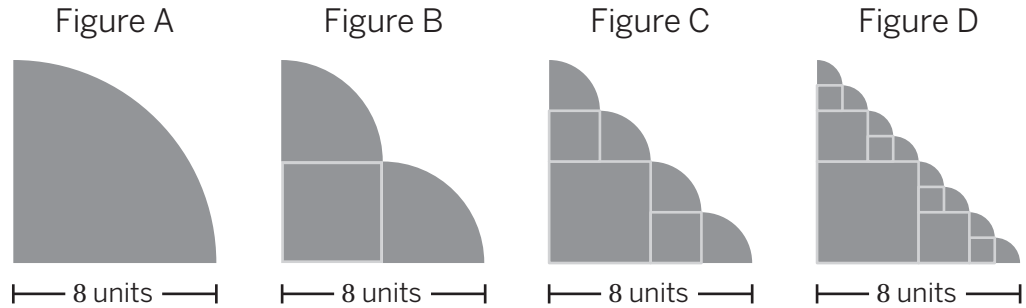

b What would be the area of the next figure of this sequence?

c Could there be a figure with an area of 30 square units?

3

The square has side lengths of 10 units. Two arcs, parts of a circle, are shown with the center of each circle at *A* and *C*. Determine the area of the shaded region.

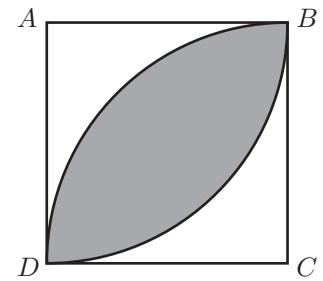

Assign problems to students who want to extend their thinking.

Problems 1, 2 and 3 can be solved in any order. If time allows, consider sharing Problems 1 and 2 with all students.

Problem 1

Students will extend their understanding of area by calculating the areas of a series of circular figures.

Provide students with the following hint if additional scaffolding is needed.

- **Hint:** How do you determine the radius of smaller circles?

a. Figure A: $\frac{3 \cdot \pi \left(\frac{r}{3}\right)^2}{\pi r^2} = \frac{1}{3}$

Figure B: $\frac{4 \cdot \pi \left(\frac{r}{4}\right)^2}{\pi r^2} = \frac{1}{4}$

Figure C: $\frac{5 \cdot \pi \left(\frac{r}{5}\right)^2}{\pi r^2} = \frac{1}{5}$

Figure D: $\frac{6 \cdot \pi \left(\frac{r}{6}\right)^2}{\pi r^2} = \frac{1}{6}$

b. $\frac{1}{7}$

Explanations vary.

- If there are n small circles, the area of the shaded region is $n - 1$ times the total area of the small circles.
- If there are n small circles, the ratio of unshaded region to the entire circle is $\frac{1}{n}$.

Problem 2

Students will extend their understanding of area by calculating the areas of a series of circular figures.

Provide students with the following hints if additional scaffolding is needed.

- **Hint:** How does the number of quarter circles increase?
- **Hint:** How does the radius of quarter circles change?

a.

Figure A	Figure B
$\frac{64\pi}{4} = 16\pi$	$16 + \frac{16\pi}{2}$ $16 + 8\pi$
Figure C	Figure D
$16 + 2 \cdot 4 + 4\pi$ $24 + 4\pi$	$16 + 2 \cdot 4 + 4 \cdot 1 + 2\pi$ $28 + 2\pi$

b. Figure E: $30 + \pi$

- c. No, the next shape will have an area of $31 + \frac{\pi}{2}$.

Continued next page ...

Problem 3

Students will extend their understanding of Students will extend their understanding of the area of a circle by determining the area of a shape that includes circular parts.

Provide students with the following hint if additional scaffolding is needed.

- **Hint:** Draw the diagonal BD of the square. How can it help you to determine the area of the shaded region?

$50\pi - 100$ or approximately 57.08 square units. *Explanations vary.*

This is the area of two one-quarter circles subtracted by the area of the square.

$$2 \cdot \frac{1}{4} (\pi \cdot 10^2) - (10 \cdot 10)$$

$$\frac{1}{2} (100\pi) - (100)$$

$$50\pi - 100$$

The area of the shaded region is $50\pi - 100 \approx 57.08$ square units.

Unit 4

Extensions

Name: Date: Period:

Student Choice

Remember to show or explain your thinking.

1

A shop is experimenting with increasing and decreasing the prices of their items. What is the final price of a sweatshirt that had a price of \$32.50 if...

- a** The price was increased by 10%, then that price was decreased by 10%?
- b** The price was decreased by 10% first and then increased by 10%?
- c** The price was increased by 20%, then decreased by 20%. Will the price be more or less than the original price?
- d** The price was decreased by 20%, then decreased by 30%. How would this compare to a decrease of 50%?

2

Egypt's population is about 100 million, and it grows by approximately 2% every year. If it continues growing at this same rate, determine how many years it will take to reach a population of 120 million.

Name: Date: Period:

3

Truchet tiles are tiles that are designed so that when placed in a grid they generate interconnecting patterns. A common form of the Truchet tiles decorates each tile with two quarter-circles connecting the midpoints of adjacent sides

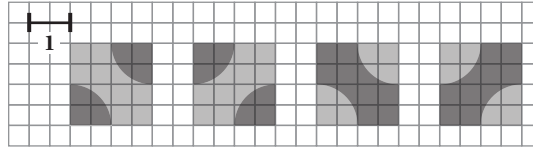

- a** What percent of each 16 by 16 square is shaded darker gray?

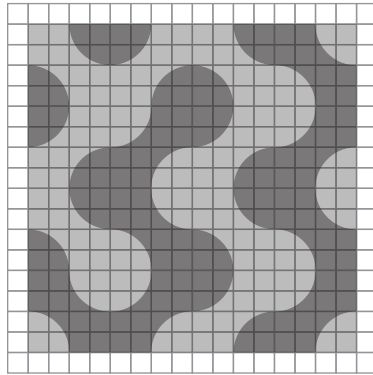

..... %

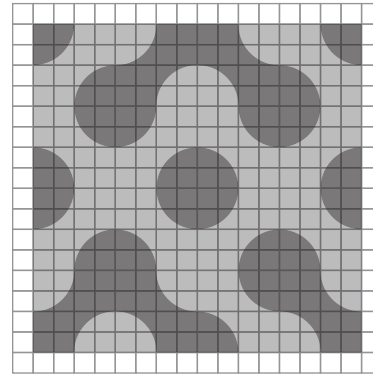

..... %

- b** Decorate each square so that the darker gray region is approximately 45% and 60% of each square respectively.

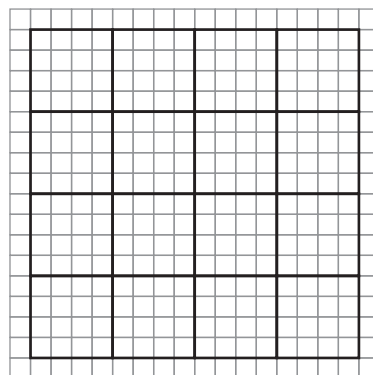
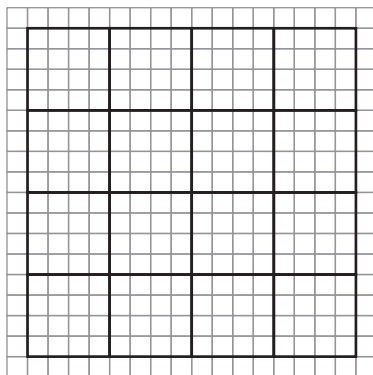

Assign problems to students who want to extend their thinking.

Assign Problem 2 to students who have solved Problem 1. If time allows, consider sharing Problems 1 and 2 with all students.

Materials

- coloring tools (**Problem 3**)

Problem 1

Students will extend their understanding of solving problems about percent change by representing multiple percent changes with expressions.

Provide students with the following hint if additional scaffolding is needed.

- Hint:** If the price of the t-shirt had first been increased by 100%, then decreased by 100%, write an expression to represent the final price of the t-shirt.

a. **\$32.18**

b. **\$32.18**

c. **Less.**

Explanations vary. Let's represent the price of the tshirt using p .
 $1.2p \cdot 0.8 = 0.96p$

d. **The 50% discount will be cheaper.**

Explanations vary. Let's represent the price of the tshirt using p .
The price of the t-shirt after the discounts is $0.7p \cdot 0.8 = 0.56p$,
and the other discount option is $0.50p$.

Problem 2

Students will extend their understanding of solving percent problems by determining the number of years for a population to reach a certain value.

Provide students with the following hint if additional scaffolding is needed.

- Hint:** Can you write an equation to generalize this scenario? What is your variable? What does it represent?

A little more than 9 years.

Explanations vary. After one year, I calculated $1.02 \cdot 100 = 102$ million.
After two years, $1.02 \cdot 102 = 104.04$ million. I continued the pattern until I saw that between 9 and 10 years the population will hit 120 million.

Continued next page ...

Problem 3

Students will extend their understanding of percents and area by designing square tiles.

Provide students with the following hints if additional scaffolding is needed.

- **Hint:** Determine the area of each square and quarter circle. How many different color areas are there?

a. 50% and ~46%

b. Drawings vary.

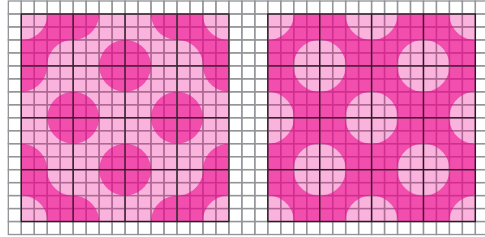

Name: Date: Period:

Student Choice

Remember to show or explain your thinking.

1

Amy sold two sofas at a price of \$1,200 a piece. She made a 25% profit on the first sofa and a 20% loss on the other. She assumed that she still made a profit on the combined sale. Is she correct?

2

- a** Dinner at a restaurant costs \$23.74. The sales tax is 10% and the customer plans to tip 20%. How much more expensive is it to pay the tip with the tax already included, rather than pay the tip first without the tax included?
- b** The cost of a meal at the restaurant is c dollars, the sales tax is 10% and the customer plans to tip 20%. Write an expression to represent how much more expensive it would be for the customer to pay the tip on the price the tax, instead of the cost of the meal without the tax.

Name: Date: Period:

3

From 22 kg of fresh mushrooms, 2.5 kilogram of dried mushrooms are obtained, containing 12% water. What is the percentage of water in the fresh mushrooms?

Assign problems to students who want to extend their thinking.

Assign Problem 2 to students who have solved Problem 1. If time allows, consider sharing Problems 2 and 3 with all students.

Problem 1

Students will extend their understanding of using equations to solve problems about percent change by representing multiple percent changes with expressions.

Provide students with the following hints if additional scaffolding is needed.

- **Hint:** How can you determine the cost price of the first sofa? The second sofa?
- **Hint:** What is the total cost price of two sofas?

The pricing of the first sofa:

$x \cdot \frac{125}{100} = 1.25x$, $1.25x = 1,200$. The cost of the first sofa is \$960.

The pricing of the second sofa: $y \cdot \frac{80}{100} = 0.8x$, $0.8x = 1,200$. The cost of the first sofa is \$1,500.

Total cost price is $960 + 1500 = 2460$, total selling price is $1200 + 1200 = 2400$. To determine if there was a profit or loss, subtract the total cost price from the total selling price $\text{Total selling price} - \text{Total cost price} = 2400 - 2460 = -60$. A negative result indicates a loss. Therefore, Amy actually incurred a loss of \$60 on the combined sale.

Problem 2

Students will extend their understanding of sales tax and tips by comparing the cost of tipping before and after sales tax.

Provide students with the following hint if additional scaffolding is needed.

- **Hint:** What is the cost of the dinner including tax?

a. \$0.48. *Explanations vary.*

The cost of the meal with the tip on top of the tax can be calculated by $23.74 \cdot 1.1 \cdot 1.2$, which results in a total cost of \$31.34.

The cost of the meal with the tip determined before the tax can be calculated by $23.74 \cdot 0.2 + 23.74 \cdot 1.1$, which results in about \$30.86.

The difference is $30.86 - 31.34$.

b. 0.02c. *Explanations vary.* The cost of the meal with the tip on top of the tax can be calculated by $c \cdot 1.1 \cdot 1.2 = 1.32c$.

The cost of the meal with the tip determined before the tax can be calculated by $c \cdot 0.2 + c \cdot 1.1 = 1.3c$. The difference is $1.32c - 1.3c = 0.02c$.

Continued next page ...

Problem 3

Students will extend their understanding of solving problems about percent change with multiple percent changes.

Provide students with the following hint if additional scaffolding is needed.

- **Hint:** Determine the percent of dried mushrooms that can be obtained from fresh mushrooms.

$2.5 \cdot 0.88 = 2.2$ kg completely dried mushrooms.

Explanations vary. I checked what % of fresh mushrooms is dried by multiplying $2.2 \cdot \frac{100}{22} = 10$, so 10% of the mushroom is dried and 90% of the mushroom is water.

Name: Date: Period:

Student Choice

Remember to show or explain your thinking.

1

A *repeating decimal* is a value where one or more of its digits eventually form a string of numbers that repeats forever, such as $0.181818\dots$, which we represent as $0.\overline{18}$. A *terminating decimal* has digits that do not repeat forever, such as 0.625 .

- a** Take a look at the fractions below. Which ones do you think can be written as a terminating decimal?

$\frac{2}{3}$	$\frac{3}{5}$	$\frac{3}{12}$	$\frac{5}{12}$	$\frac{7}{8}$	$\frac{5}{6}$	$\frac{13}{25}$	$\frac{9}{16}$	$\frac{3}{125}$	$\frac{35}{32}$	$\frac{9}{7}$

- b** What do you notice about the ones that repeat vs. terminate?

2

Here are some calculations for the fraction to decimal conversions.

$$\frac{1}{9} = 0.11111\dots \quad \frac{1}{99} = 0.0101010\dots \quad \frac{1}{999} = 0.00100100100\dots$$

The decimal representations of $\frac{1}{9}$, $\frac{1}{99}$, and $\frac{1}{999}$ can be used to help you work out the decimal representations of other families of fractions.

Can you use what you now know to make predictions about the decimal representations of these and other fractions?

- a** $\frac{1}{3}$, $\frac{1}{33}$, $\frac{1}{333}$
- b** $\frac{1}{11}$, $\frac{1}{111}$, $\frac{1}{1111}$
- c** $\frac{13}{99}$, $\frac{28}{99}$, $\frac{54}{99}$

Name: Date: Period:

3

- a** Use a calculator to convert sevenths to decimals.

Fraction	Decimal	Fraction	Decimal
$\frac{1}{7}$	0.1428571428571428... 0.142857	$\frac{4}{7}$	
$\frac{2}{7}$		$\frac{5}{7}$	
$\frac{3}{7}$		$\frac{6}{7}$	

- b** What did you notice?
- c** Diego used sevenths circles to make the conversions. Can you explain how it works?

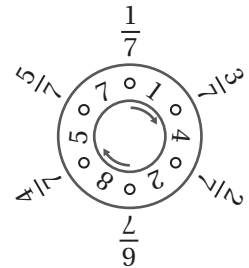

Proportional Relationships with
Fractions and Decimals

Assign problems to students who want to extend their thinking.

Problems 2 and 3 can be solved in any order. Assign Problem 3 to students who have solved Problem 1. If time allows, consider sharing Problems 1 and 2 with all students.

Problem 1

Students will extend their understanding of converting fractions to decimals using long division and examining patterns.

Provide students with the following hint if additional scaffolding is needed.

- **Hint:** How can you determine if a fraction can be written as a terminating or repeating decimal?

a.

$\frac{2}{3}$	$\frac{3}{5}$	$\frac{3}{12}$	$\frac{5}{12}$	$\frac{7}{8}$	$\frac{5}{6}$
R	T	T	R	T	R

$\frac{13}{25}$	$\frac{9}{16}$	$\frac{3}{125}$	$\frac{35}{32}$	$\frac{9}{7}$
T	T	T	T	R

b. Responses vary.

- When the denominators of the simplest form of terminating fractions are factored, I got the numbers 2, 5 or both.
- To get a repeating decimal, the denominator of the fraction must be 3, 7, 9, 11, 13...
- If the denominator is factored as $3 \cdot 2$ or $5 \cdot 7$, it still gives the repeating decimal.

Continued next page ...

Problem 2

Students will extend their understanding of comparison properties by solving the pentagon puzzle.

Provide students with the following hint(s) if additional scaffolding is needed.

- **Hint:** How can you rewrite these fractions in terms of $\frac{1}{9}$, $\frac{1}{99}$, and $\frac{1}{999}$?

- a. $\frac{1}{3} = \frac{3}{9}$ so it is 0.3333 ...
 $\frac{1}{33} = \frac{3}{99}$ so it is 0.030303 ...
 $\frac{1}{333} = \frac{3}{999}$ so it is 0.003003003 ...
- b. $\frac{1}{11} = \frac{9}{99}$ so it is 0.090909 ...
 $\frac{1}{111} = \frac{9}{999}$ so it is 0.009009009 ...
 $\frac{1}{1111} = \frac{9}{9999}$ so it is 0.000900090009 ...
- c. $\frac{13}{99} = 0.131313 ...$
 $\frac{28}{99} = 0.282828 ...$
 $\frac{54}{99} = 0.545454 ...$

Problem 3

Students will extend their understanding of terminating and repeating decimals by exploring sevenths.

Provide students with the following hint if additional scaffolding is needed.

- **Hint:** What are the digits that keep repeating in each decimal form of sevenths?

- a. $\frac{1}{7} = 0.\overline{142857}$
 $\frac{2}{7} = 0.\overline{285714}$
 $\frac{3}{7} = 0.\overline{428571}$
 $\frac{4}{7} = 0.\overline{571428}$
 $\frac{5}{7} = 0.\overline{714285}$
 $\frac{6}{7} = 0.\overline{857142}$
- b. *Responses vary.*
- Sevenths have the same numbers repeating in different orders.
 - Multiples of 142857 are
- | | |
|---------------------------|---------------------------|
| $142857 \cdot 2 = 285714$ | $142857 \cdot 4 = 571428$ |
| $142857 \cdot 3 = 428571$ | $142857 \cdot 5 = 714285$ |
- c. *Responses vary.*
- Follow the digits in clockwise direction after the numerator to write the expansion. For example, in clockwise direction, after 4, the numbers are 5 – 7 – 1 – 4 – 2 – 8, so $\frac{4}{7} = 0.\overline{571428}$.

Unit 5

Extensions

Name: Date: Period:

Student Choice Remember to show or explain your thinking.**1**

Here are magic squares with positive and negative integers. Determine the unknown numbers.

a

		-1
2	0	
1	-4	

b

-4		
	-1	
	-3	2

c

0	-7	
-5		
-4		

2

Use the numbers -2, -1, 0, 1, 2 to complete the Kenken puzzle.

- Every row and column must use one of -2, -1, 0, 1, 2 only once.
- Each region must have the indicated result at the top left corner.
- For example, the *difference* (operation after the number) of the top left L-shape made up of three squares must be 0.

0-		-3+		0÷
0x		1+	3-	
	0x			3+
0-		1	0x	
		0		-1

3

Determine the sums. What patterns do you notice?

a $-1 + 2 - 3 + 4 - 5 + 6 - 7 + 8 \dots -97 + 98 - 99 + 100$

b $1 - 2 + 3 - 4 + 5 - 6 + 7 - 8 \dots + 97 - 98 + 99 - 100$

Name: Date: Period:

4

Consider the following figure. For the numbers a and b , which expression is equivalent to $|a + b|$?

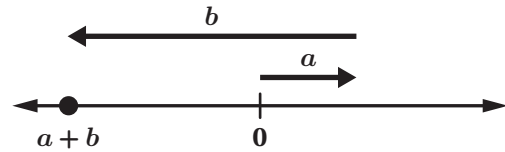

- a $|a| + |b|$
- b $|a| - |b|$
- c $|b| - |a|$

5

Determine the following sums.

- a $\frac{1}{2} + \frac{1}{4} + \frac{1}{8} + \frac{1}{16}$
- b $\frac{1}{3} + \frac{1}{9} + \frac{1}{27} + \frac{1}{81}$
- c $\frac{1}{4} + \frac{1}{16} + \frac{1}{64} + \frac{1}{256}$
- d Following the pattern in parts a–c, determine the value of $\frac{1}{5} + \frac{1}{25} + \frac{1}{125} + \frac{1}{625}$.

Continue the patterns to estimate each sum if it continues infinitely.

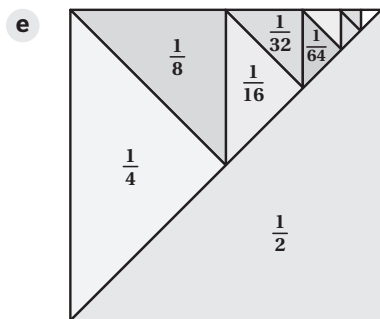

$$\frac{1}{2} + \frac{1}{4} + \frac{1}{8} + \frac{1}{16} + \frac{1}{32} + \dots$$

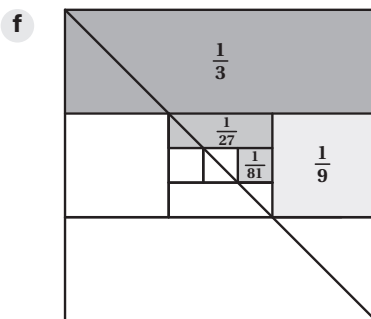

$$\frac{1}{3} + \frac{1}{9} + \frac{1}{27} + \frac{1}{81} + \frac{1}{243} + \dots$$

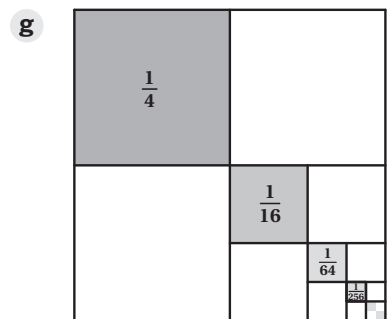

$$\frac{1}{4} + \frac{1}{16} + \frac{1}{64} + \frac{1}{256} + \frac{1}{1024} + \dots$$

- h What do you notice about the infinite sums in parts e–g? Can you estimate the sum of $\frac{1}{n} + \frac{1}{n^2} + \frac{1}{n^3} + \frac{1}{n^4} + \dots$

Assign problems to students who want to extend their thinking.

Problems 1 and 3–5 can be solved in any order. Assign Problem 2 to students who have solved Problem 1. If time allows, consider sharing Problems 2 and 5 with all students.

Problem 1

Students will extend their understanding of adding and subtracting integers by solving magic square puzzles.

Provide students with the following hint if additional scaffolding is needed.

- **Hint:** Determine the sum of each row, column, and diagonal for each of the puzzles.

a.

-3	4	-1
2	0	-2
1	-4	3

b.

-4	1	0
3	-1	-5
-2	-3	2

c.

0	-7	-2
-5	-3	-1
-4	1	-6

Problem 2

Students will extend their understanding of adding and subtracting integers by solving a KenKen puzzle.

Provide students with the following hints if additional scaffolding is needed.

- **Hint 1:** Start with the single cells in the bottom rows.
- **Hint 2:** The top right rectangle has $0 \div$. In which cell must 0 be at?
- **Hint 3:** When inserting the zeroes for $0 \times$, remember that each row and column must have each number once.

0-	2	-3+	-1	0÷
1	2	-2	-1	0
0x	-1	1+	3-	-2
0	-1	2	1	-2
2	0x	-1	-2	3+
2	0	-1	-2	1
0-	-2	1	0x	2
-1	-2	1	0	2
-2	1	0	2	-1
-2	1	0	2	-1

Continued next page ...

Problem 3

Students will extend their understanding of evaluating expressions with integers by evaluating a complex sum.

Provide students with the following hint if additional scaffolding is needed.

- **Hint:** Determine the sum of each consecutive pair. How many pairs are there in each sum?

- a. 50. *Explanations vary.* I noticed that the difference in each pair, $-1 + 2$, $-3 + 4$, is 1. Because the expression starts with -1 and ends with 100 , I know there are 50 pairs. The sum of the 50 pairs of 1 is 50.
- b. -50 . *Explanations vary.* I noticed that the difference in each pair, $1 - 2$, $3 - 4$, is -1 . Because the expression starts with $+1$ and ends with -100 , I know there are 50 pairs. The sum of the 50 pairs of -1 is -50 .

Problem 4

Students will extend their understanding of adding positive and negative numbers by determining which absolute value expression is equivalent to the arrow diagram shown.

Provide students with the following hint if additional scaffolding is needed.

- **Hint:** Consider substituting a and b with positive and negative numbers.

- c. *Explanations vary.*
- I substituted the values $b = -10$ and $a = 3$ to make sense of the diagram. Therefore $a + b = -7$ and $|a + b| = 7$. The expression that results in 7 is $|b| - |a|$ because $|a| + |b| = 13$ and $|a| - |b| = -7$.

Problem 5

Students will extend their understanding of adding and subtracting rational numbers by estimating the infinite sums of fractions.

Provide students with the following hint if additional scaffolding is needed.

- **Hint:** In parts e–g, consider that the addends go to infinity. How much of the remaining region will be shaded.

- a. $\frac{15}{16}$ b. $\frac{40}{81}$
- c. $\frac{85}{256}$ d. $\frac{156}{625}$
- e. 1. *Explanations vary.* If we keep adding fractions with the denominators of powers of 2, I think that the entire square will be covered.
- f. $\frac{1}{2}$. *Explanations vary.* If we keep adding fractions with the denominators of powers of 3, I think a half of the square will be covered.
- g. $\frac{1}{3}$. *Explanations vary.* If we keep adding fractions with the denominators of powers of 4, I think that the $\frac{1}{3}$ of the square will be covered.
- h. $\frac{1}{n-1}$. *Explanations vary.* By looking at the sums in parts e–g, the ratio of the total shaded regions by the fractions is always 1 less than the denominator.

Name: Date: Period:

Student Choice

Start with any problem. Remember to show or explain your thinking.

1

Here is a group of six integers. Try to determine all the different ways to make the product equal -1 and 1.

$$\square \cdot \square \cdot \square \cdot \square \cdot \square \cdot \square$$

- a** For a group of six integers that multiply to equal 1, which of the following cannot be their sum?

A. -6 **B.** -2 **C.** 0 **D.** 2 **E.** 6

- b** For a group of six integers that multiply to equal -1, which of the following cannot be their sum?

A. -6 **B.** -4 **C.** 0 **D.** 4

2

Determine the sums.

a $(-1)^0 + (-1)^1$

b $(-1)^0 + (-1)^1 + (-1)^2 + (-1)^3$

c $(-1)^0 + (-1)^1 + (-1)^2 + (-1)^3 + \dots + (-1)^{98} + (-1)^{99}$

3

a , b , and c are integers. If $-7 < a < 3$, $0 < b < 8$, and $-4 < c < 2$, determine the least possible value of $\frac{a \cdot b}{c}$.

Name: Date: Period:

4

The following sequence of rational numbers is created by starting with 1. From then on, each term follows this pattern:

$$1 \quad 1 + \frac{1}{1} \quad 1 + \frac{1}{1+1} \quad 1 + \frac{1}{1 + \frac{1}{1+1}} \quad 1 + \frac{1}{1 + \frac{1}{1 + \frac{1}{1+1}}} \dots$$

- a** Evaluate the first five expressions in the sequence. Describe any patterns you notice.
- b** Predict the value of the next expression in the sequence.
- c** Determine the 10th term in this sequence.

5

Fill the blank with any whole number.

$$a = \frac{1}{2 \times \square + 1}$$

Simplify your fraction for a , then substitute it in the expression:

$$\frac{1+a}{1-a}$$

Try different whole numbers to determine a rule for any whole number.

Assign problems to students who want to extend their thinking.

Problems 1–5 can be solved in any order. If time allows, consider sharing Problems 3 and 5 with all students.

Problem 1

Students will extend their understanding of multiplying and dividing rational numbers by exploring the properties of the given products.

Provide students with the following hint if additional scaffolding is needed.

- **Hint:** Consider writing different lists of numbers. What do they have in common?

1. *Explanations vary.* Possible groups of six integers whose product is 1 are

$$1 \cdot 1 \cdot 1 \cdot 1 \cdot 1 \cdot 1$$

$$(-1) \cdot (-1) \cdot (-1) \cdot (-1) \cdot (-1) \cdot (-1)$$

$$1 \cdot 1 \cdot (-1) \cdot (-1) \cdot (-1) \cdot (-1)$$

$$1 \cdot 1 \cdot 1 \cdot 1 \cdot (-1) \cdot (-1)$$

- a. **C. 0 cannot be the sum.** *Explanations vary.* In all of them, there must be an even number of -1s so the product can stay positive. The sums are

$$1 + 1 + 1 + 1 + 1 + 1 = 6,$$

$$(-1) + (-1) + \dots + (-1) + (-1) = -6,$$

$$1 \cdot 1 + (-1) + (-1) + (-1) + (-1) = -2,$$

$$1 + 1 + 1 + 1 + (-1) + (-1) = +2.$$

- b. **A. -6 cannot be the sum.** *Explanations vary.* This time for the product to be negative, there must be an odd number of -1s. The possibilities and their sums are

$$1 + (-1) + (-1) + (-1) + (-1) + (-1) = -4$$

$$1 + 1 + 1 + (-1) + (-1) + (-1) = 0$$

$$1 + 1 + 1 + 1 + 1 + (-1) = 4$$

Problem 2

Students will extend their understanding of multiplying rational numbers by exploring the properties of powers of (-1).

Provide students with the following hint if additional scaffolding is needed.

- **Hint:** In part c, determine the sums of consecutive pairs.

- a. **0.**
 $1 + (-1) = 0$
 b. **0.**
 $1 + (-1) + 1 + (-1) = 0$
 c. **0.**

Explanations vary. All odd powers of (-1) are equal to -1, and all even powers of (-1) are equal to +1. So each consecutive pair equals zero.

$$1 + (-1) + 1 + (-1) + \dots + 1 + (-1) = 0$$

Continued next page ...

Problem 3

Students will extend their understanding of multiplying and dividing rational numbers by choosing the best possible integers to create the least value of the given quotient.

Provide students with the following hints if additional scaffolding is needed.

- **Hint 1:** Should you aim to create a negative or a positive quotient?
- **Hint 2:** Do you need to maximize the value of the denominator or the numerator?

-42. *Explanations vary.*

When $a = -6$, $b = 7$, and $c = 1$, I can calculate the minimum value of the quotient as $\frac{(-6) \cdot 7}{1} = -42$

Problem 4

Students will extend their understanding of rational numbers by evaluating and extending a sequence with complex fractions.

Provide students with the following hints if additional scaffolding is needed.

- **Hint 1:** In part a, It might be easier to spot the pattern if you represent each expression as a single fraction.
- **Hint 2:** How is the numerator of the fourth fraction in the sequence related to the numerator and the denominator of the third fraction?

a. $1, 2, \frac{3}{2}, \frac{5}{3}, \frac{8}{5}$

Responses vary. The previous numerator becomes the new denominator, and the new numerator is the result of adding the previous numerator and denominator together.

b. $\frac{13}{8}$

c. $\frac{89}{55}$

Explanations vary.

- Using the pattern, I was able to list out the first ten terms, $1, 2, \frac{3}{2}, \frac{5}{3}, \frac{8}{5}, \frac{13}{8}, \frac{21}{13}, \frac{34}{21}, \frac{55}{34}, \frac{89}{55}$.
- The numerators and the denominators of each fraction in the pattern follows the Fibonacci sequence.

Problem 5

Students will extend their understanding of dividing rational numbers by generalizing a rule about the given quotient.

Provide students with the following hint if additional scaffolding is needed.

- **Hint:** Start from 1 and use a table to organize your results.

The quotient is $\frac{n+1}{n}$. *Explanations vary.*

$n = 1$	$n = 2$	$n = 3$	$n = 4$	$n = 5$
$\frac{2}{1}$	$\frac{3}{2}$	$\frac{4}{3}$	$\frac{5}{4}$	$\frac{6}{5}$

I tried several numbers, I noticed the quotients are always one more than the number over one less than the number.

Unit 6

Extensions

Name: Date: Period:

Student Choice

Remember to show or explain your thinking.

1

Think of a number.

Step 1: Multiply the number by 5.**Step 2:** Subtract 2.**Step 3:** Add 7.**Step 4:** Divide by 5.**Step 5:** Subtract 1 more than your original number.

- a** How will your final answer be related to your original number?
- b** Try several numbers. What did you notice?
- c** Do you get the same result if you do step 3 before step 2?

2

Change the last step in the initial magic trick in Problem 1 so that you end up with your original number.

Name: Date: Period:

3

- a** Lizzie skip counts by a number, y , starting from -4 . The fourth number she says is 35, what is the value of y ?
- b** Lizzie skip counts by 5 starting from x . The sum of the first five numbers she says is 65, what is the value of x ?

4

In the diagram shown, each individual rectangle has dimensions 10 centimeters by 5 centimeters. If Figure n has a perimeter of 500 centimeters, determine the value of n .

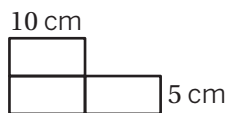
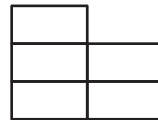
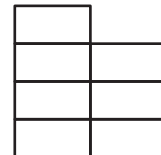
Figure 1**Figure 2****Figure 3**

Assign problems to students who want to extend their thinking.

Problems 1 and 3–4 can be solved in any order. Assign Problem 2 to students who solved Problem 1. If time allows, consider sharing Problems 3 and 4 with all students.

Problem 1

Students will extend their understanding of equations by redesigning a magic trick.

Provide students with the following hint if additional scaffolding is needed.

- **Hint:** In part b, let the original number be x . How can you express the steps of the magical trick in terms of x ?

- I ended up with 0. Explanations vary. I picked 8 to start. After the fifth step $\frac{8 \cdot 5 - 2 + 7}{5} - 9 = 0$, I ended up with 0.**
- Responses vary. Let the original number be x , then $\frac{5x - 2 + 7}{5}$ is $\frac{5(x + 1)}{5}$, which equals to $x + 1$. If I subtract $x + 1$, I will always end up with 0.**
- Responses vary. When I changed the order of the second and third steps, nothing changed. $\frac{8 \cdot 5 + 7 - 2}{5} - 9 = 0$**

Problem 2

Students will extend their understanding of equations by redesigning a magic trick.

Provide students with the following hint if additional scaffolding is needed.

- **Hint:** What do you need to subtract in the last step instead of $x + 1$?

Responses vary. If I subtract 1 instead of subtracting 1 more than the original number, I will end up with the original number. Let the original number be x , then $\frac{5x - 2 + 7}{5}$ is $\frac{5(x + 1)}{5}$ which equals to $x + 1$. If I subtract 1, I will end up with the original number no matter what that number is.

Continued next page ...

Problem 3

Students will extend their understanding of reasoning about equations by writing and solving equations with repeated multiplication and addition.

Provide students with the following hint if additional scaffolding is needed.

- **Hint:** In part a, what is the second number in the sequence? The third number will be y more than the second one. How can we write an expression to simplify the sum?

- a. **13. Explanations vary.**
The sequence is $-4, (-4 + y), (-4 + 2y), (-4 + 3y) \dots$
If the fourth number is 35, then $-4 + 3y = 35$, so $y = 13$.
- b. **3. Explanations vary.** The sequence is $x, (x + 5), (x + 10), (x + 15), (x + 20) \dots$
If the sum of first five numbers is 65, then $5x + 50 = 65$, so $x = 3$.

Problem 4

Students will extend their understanding of reasoning about solving equations by using algebra to investigate patterns.

Provide students with the following hints if additional scaffolding is needed.

- **Hint 1:** Determine the number of longer sides and the shorter sides in each figure. How do they increase?
- **Hint 2:** Consider drawing the next figures if it helps you figure out the pattern.

45. Explanations vary. In each figure the number of longer sides stays the same, the number shorter sides increase by 2.

Figure	Perimeter
1	$4 \cdot 10 + 4 \cdot 5 = 60$
2	$4 \cdot 10 + 6 \cdot 5 = 70$
3	$4 \cdot 10 + 8 \cdot 5 = 80$
4	$4 \cdot 10 + 10 \cdot 5 = 90$
n	$4 \cdot 10 + (2n + 2) \cdot 5 = 500$

By solving $4 \cdot 10 + (2n + 2) \cdot 5 = 500$,

$$5(2n + 2) = 460$$

$$2n + 2 = 92$$

$$2n = 90$$

$$n = 45$$

Name: Date: Period:

Student Choice

Remember to show or explain your thinking.

1

Consider the calendar and the date highlighted, May 8.

- a** Look at the numbers above, below, and to either side of the 8th. Calculate the mean of these numbers. What do you notice?
- b** Repeat part a by choosing a different date. Explain why the same thing will happen for any date in a location where it has a date above, below, and to either side.
- c** Assume you cover four dates next to May 8 with a square. Determine the difference of product of the corner numbers, i.e., $8 \cdot 2 - 1 \cdot 9$. Repeat by choosing different dates. What do you notice?
- d** Explain why the same thing will happen for any date.

Sun	Mon	Tue	Wed	Thu	Fri	Sat
		1	2	3	4	5
6	7	8	9	10	11	12
13	14	15	16	17	18	19
20	21	22	23	24	25	26
27	28	29	30	31		

Sun	Mon	Tue	Wed	Thu	Fri	Sat
		1	2	3	4	5
6	7	8	9	10	11	12
13	14	15	16	17	18	19
20	21	22	23	24	25	26
27	28	29	30	31		

2

You have an unknown number, x . In the first step, you add 1 then halve the sum. In the second step, you add 1 to that and halve the sum again.

- a** Write an expression to represent the first two steps of this situation.
- b** Continue adding 1 and halving the previous sum for the steps below. What did you notice?

3rd step

4th step

5th step

Name: Date: Period:

3 In an expression pyramid, each box is the sum of the two boxes under it. Complete the pyramids using the given expressions.

a

$2x + 1$	$2x$	$1 - x$
$3x - 1$	$3 - 2x$	$x - 2$

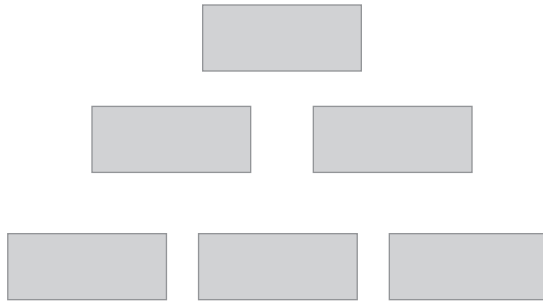

b

$-(y + 1)$	$2y$	$2(1 - x)$
$3(y - 1)$	$\frac{6 - 2y}{2}$	2

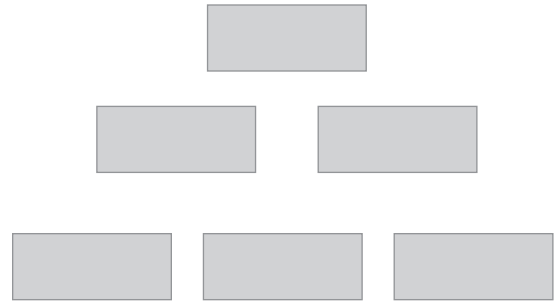

Assign problems to students who want to extend their thinking.

Problems 1 and 2 can be solved in any order. Assign Problem 3 to students who have solved Problem 1 or 2. If time allows, consider sharing Problems 3 with all students.

Problem 1

Students will extend their understanding of reasoning about solving equations by using algebra to investigate patterns.

Provide students with the following hints if additional scaffolding is needed.

- **Hint 1:** In part b, let the original date be x how can you express the date below in terms of x ? The date above?
- **Hint 2:** In part d, consider using area models to help you multiply two two-term expressions.

- a. **8. Responses vary.** The mean of these four numbers is equivalent to the value of the date selected.
- b. **Responses vary.** I chose the date of 21 and the mean for the values above, below, and on either side resulted in 21. The mean of these values is equivalent to the value of the date selected.

If the original date chosen is represented by x , then the data above is $x - 7$, because it is 7 days prior. The date below is $x + 7$, because it is 7 days after. The date to the left is $x - 1$ and the date to the right is $x + 1$. The sum of these four dates is $(x - 7) + (x + 7) + (x - 1) + (x + 1)$ which equals $4x$. To calculate the mean, I would divide this by 4, resulting in x , the original date chosen.

- c. **Responses vary.** $8 \cdot 2 - 1 \cdot 9 = 7$. Then I chose May 10, the difference is again $10 \cdot 4 - 3 \cdot 11 = 7$. No matter which date I choose, the difference is always 7.
- d. **Explanations vary.** If the original date chosen is represented by x , the difference of the products of the corner numbers is $[x \cdot (x - 6)] - [(x - 7)(x + 1)]$
 $= [x^2 - 6x] - [x^2 - 6x - 7] = 7$

Problem 2

Students will extend their understanding of expanding and factoring by expanding a pattern using the fewest number of terms.

Provide students with the following hint if additional scaffolding is needed.

- **Hint:** One way to write the first step is $(x + 1) \cdot \frac{1}{2}$. The other way, which might be more helpful here, is using distributive property to write the result as a ratio, $\frac{x+1}{2}$. Consider using the same method for the following steps.

- a. First step: $\frac{x+1}{2}$
 Second step: $\frac{\frac{x+1}{2}+1}{2} = \frac{x+3}{4}$

- b.
- | | | |
|---|---|---|
| 3rd step | 4th step | 5th step |
| $\frac{\frac{x+3}{4}+1}{2} = \frac{x+7}{8}$ | $\frac{\frac{x+7}{8}+1}{2} = \frac{x+15}{16}$ | $\frac{\frac{x+15}{16}+1}{2} = \frac{x+31}{32}$ |

Each step has the power of 2 as the denominator and one less than that as the constant in the numerator. For example, in step 8, it will be $\frac{x+(2^8-1)}{2^8}$.

Continued next page ...

Problem 3

Students will extend their understanding of

expressions by adding, expanding, and factoring to complete the expression pyramid.

Provide students with the following hint if additional scaffolding is needed.

- **Hint:** In part b, writing each expression using fewer number of terms or as sum expressions can help determine the sums of two boxes.

a.

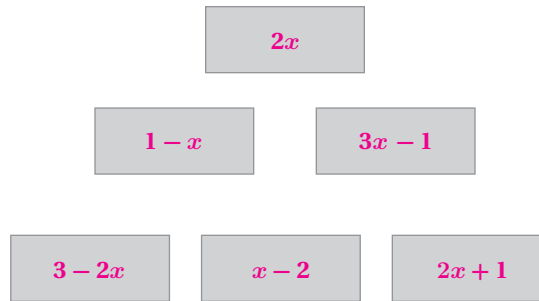

b.

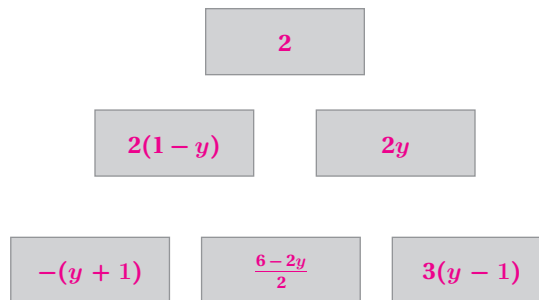

Name: Date: Period:

Student Choice Pick any problem to start with. Remember to explain your thinking.

1

Write an integer in each pentagon so that all arrows go from a larger number to a smaller number.

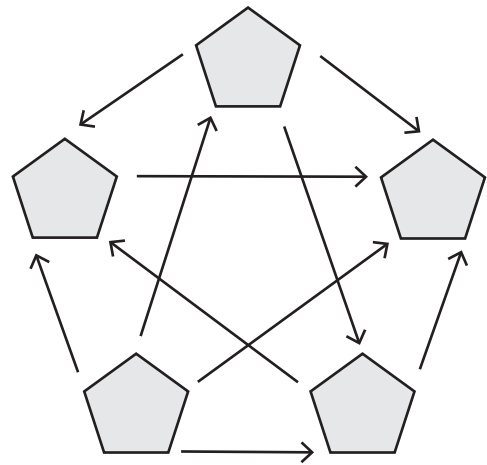

2

Using the numbers from 1–9 at most once, fill in the boxes so that the solution to each inequality is $x \leq 2$.

a Create an inequality.

$$\square x - \square \leq \square$$

b Create two inequalities.

$$\square x - \square \leq \square$$

$$\square x - \square \leq \square$$

Name: Date: Period:

3

Given $a > b$ and $c > d$, identify whether each of the following statements is always true, sometimes true or never true.

Inequalities	Always True	Sometimes True	Never True	Explanation
$a + c > b + d$	<input type="checkbox"/>	<input type="checkbox"/>	<input type="checkbox"/>	
$a - c > b - d$	<input type="checkbox"/>	<input type="checkbox"/>	<input type="checkbox"/>	
$a \cdot c > b \cdot d$	<input type="checkbox"/>	<input type="checkbox"/>	<input type="checkbox"/>	
$\frac{a}{c} > \frac{b}{d}$ ($c \neq 0, d \neq 0$)	<input type="checkbox"/>	<input type="checkbox"/>	<input type="checkbox"/>	

Assign problems to students who want to extend their thinking.

Problems can be solved in any order. If time allows, consider sharing Problem 3 with all students.

Problem 1

Students will extend their understanding of comparison properties by solving the pentagon puzzle.

Provide students with the following hints if additional scaffolding is needed.

- **Hint 1:** You can use the set of numbers $\{-2, -1, 0, 1, 2\}$ if it helps with your thinking.
- **Hint 2:** Which pentagon should have the biggest number? Which pentagon should have the smallest number?

Responses vary.

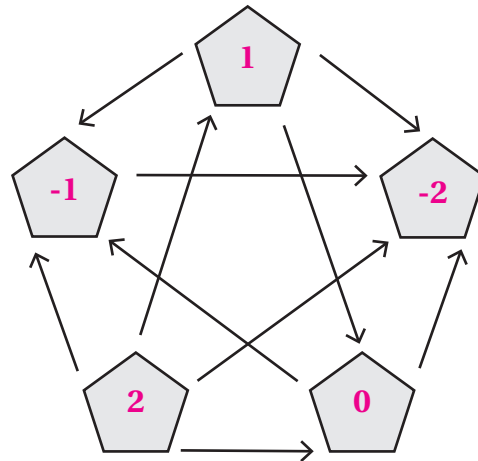

Problem 2

Students will extend their understanding of reasoning about the components of an inequality in an abstract way by creating their own inequality following certain rules.

Provide students with the following hint if additional scaffolding is needed.

- **Hint:** Use any numbers and solve the equation. Going backward, think about how you can change the numbers to get $x \leq 2$.

a. Responses vary.

Sample response:
 $7x - 9 \leq 5$

b. Responses vary.

Sample response:
 $2x - 1 \leq 3$
 $5x - 4 \leq 6$

Continued next page ...

Problem 3

Students will extend their understanding of solving inequalities by determining if the related inequality statements are true.

Provide students with the following hints if additional scaffolding is needed.

- **Hint 1:** Remember, if you think the statement is true, you need to show that it's true for any numbers a , b , c , and d where $a > b$ and $c > d$. However, it's enough to find one example of numbers a , b , c , and d for which the inequality is not true to show that the statement is false.
- **Hint 2:** a , b , c , and d can be positive or negative numbers.

- Always true. Explanations vary.**
Because $a > b$ and $c > d$, the value of $a + c$ will remain greater than $b + d$.
- Sometimes true. Explanations vary.**
 - If $a = 10$, $b = 5$, $c = 3$, and $d = 2$, then $a - c = 7$ which is more than $b - d = 3$.
 - If $a = 10$, $b = 9$, $c = 8$, and $d = 1$, then $a - c = 2$ which is less than $b - d = 8$.
- Sometimes true. Explanations vary.**
 - If $a = 10$, $b = 5$, $c = 3$, and $d = 2$, then $ac = 30$, which is more than $bd = 10$.
 - If $a = 10$, $b = 1$, $c = -1$, and $d = -3$, then $ac = -10$, which is less than $bd = -3$.
- Sometimes true. Explanations vary.**
 - If $a = 10$, $b = 5$, $c = 3$, and $d = 2$, then $a \div c = 3\frac{1}{3}$ which is more than $b \div d = 2\frac{1}{2}$.
 - If $a = 10$, $b = 9$, $c = 5$, and $d = 1$, then $a \div c = 2$ which is less than $b \div d = 9$.

Unit 7

Extensions

Name: Date: Period:

Student Choice Start with any problem. Remember to show or explain your thinking.**1**

Find the exact area of each figure below. Each square has a side length of 1 unit.

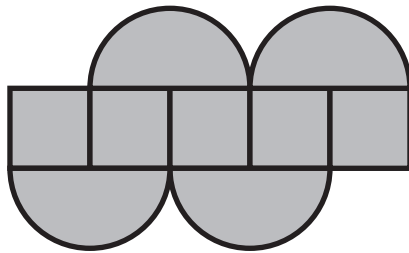
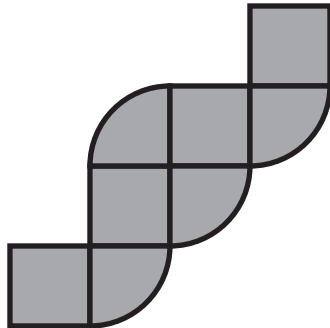
a Area = _____**b** Area = _____

Name: Date: Period:

2

Find the exact area of the shaded region of the figure below. Each square has a side length of 1 unit.

Area = _____

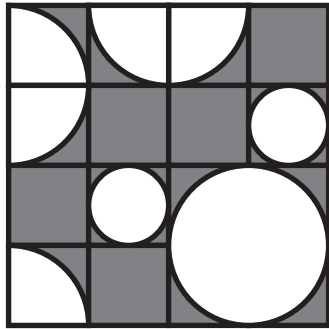

3

This is a design used in Gothic architecture called a *fleuron*. The proportion of the diameter of the large outer circle to the diameter of each of the smaller circles is 2 to 1. Calculate the ratio of the area of the region inside the large outer circle but outside the three smaller circles to the area of the large circle

Area = _____

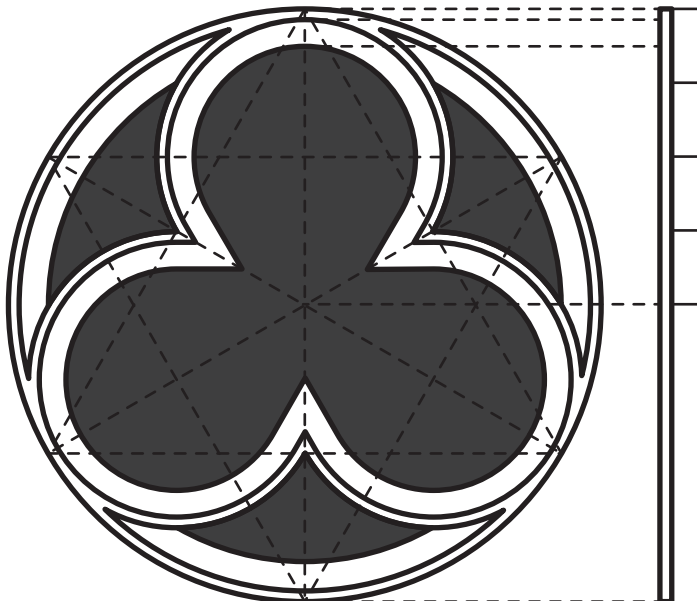

Assign problems to students who want to extend their thinking.

Problems 1, 2, and 3 can be solved in any order. If time allows, consider sharing Problems 1 and 2 with all students.

Problem 1

Students will extend their understanding of calculating the area of complex shapes by working with figures that include partial circles whose radius (or diameter) aligns with the side of a square.

Provide students with the following hints if additional scaffolding is needed.

- **Hint:** What is the relationship between the radius of a circle and the side length of the square?
- **Hint:** If you put all of the parts of the circle together, how many total circles do they make?

- a. $5 + 2\pi$ units² *Methods vary.* There are 5 squares with dimensions of 1 unit by 1 unit. That makes their total area equal to $5(1 \cdot 1) = 5$. The 4-half circles make up 2-full circles, each with a radius of 1 unit. This makes their total area equal to $2 \cdot \pi(1)^2 = 2\pi$. The combined area is $5 + 2\pi$ square units.
- b. $4 + \pi$ units² *Methods vary.* There are 4 squares with dimensions of 1 unit by 1 unit. That makes their total area equal to 4 square units. There are 4-half circles which combine to make 1 whole circle, with an area of $\pi(1)^2$ or π square units. The total area of the figure is $4 + \pi$ units².

Problem 2

Students will extend their understanding of calculating the area of the shaded area inside a figure.

Provide students with the following hints if additional scaffolding is needed.

- **Hint:** What is the relationship between the radius of a circle and the side length of the square?
- **Hint:** If you put all of the parts of the circle together, how many total circles do they make?

- $16 - \frac{11}{4}\pi$ (or equivalent) units². *Methods vary.* The large square is 4×4 or 16 square units. There are 9 quarters of a circle with a radius of 1 unit, which makes their total area equal to $9 \cdot \frac{1}{4}\pi(1)^2$ or $\frac{9}{4}\pi$. The area of the two smaller circles is $2 \cdot \pi(\frac{1}{2})^2$ or $\frac{2}{4}\pi$. The combined area of all of the circles equals $\frac{9}{4}\pi + \frac{2}{4}\pi = \frac{11}{4}\pi$. Subtracting that from the area of the square results in $16 - \frac{11}{4}\pi$ units².

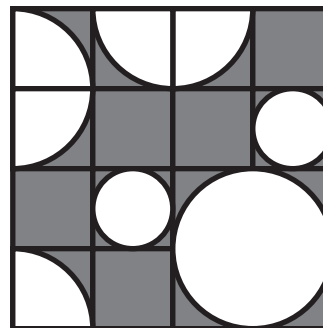

Continued next page ...

Problem 3

Students will extend their understanding of calculating the area of proportional objects.

Provide students with the following hints if additional scaffolding is needed.

- **Hint:** What if the diameter of the large outer circle was 4 inches?

3. **1 : 4 (or equivalent). Methods vary.** The area of the large circle has a diameter two times the radius of the smaller circles. We can use the equivalent ratio of 4 : 2 so that we are working with whole number ratios for the radii of each circle. The area of the large circle is $\pi(2)^2$ or 4π . The area of the three small circles is $3 \cdot \pi(1)^2$ or 3π . The area inside the large circle that is outside the three small circles is $4\pi - 3\pi = \pi$ units². The ratio of the region inside the large circle but outside the three smaller circles is $\frac{\pi}{4\pi} = \frac{1}{4}$.

Name: Date: Period:

Student Choice Start with any problem. Remember to show or explain your thinking.

1

Archimedes made many significant mathematical discoveries, but he was most proud of his work involving a sphere inscribed in a cylinder. According to a legend, he even requested that his tombstone feature this discovery!

Determine the ratio of the volume of the sphere to the volume of the cylinder when the sphere is perfectly inscribed within the cylinder. ($V_{cylinder} = \pi \cdot r^2 \cdot h$, $V_{sphere} = \frac{4}{3} \pi \cdot r^3$)

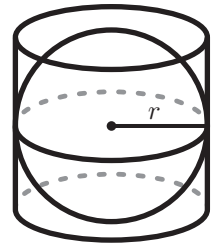

2

Rod designs an hourglass that is made up of three parts: a cylinder, a sphere, and a cone, all with the same radius r .

Determine the height h of the cylinder and the cone so that the sand from the cylinder completely fills the sphere and the cone.

$$(V_{cylinder} = \pi \cdot r^2 \cdot h, V_{sphere} = \frac{4}{3} \pi \cdot r^3, V_{cone} = \frac{1}{3} \pi r^2 h)$$

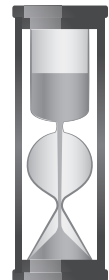

3

A frustum is the result of taking a cone and slicing off a smaller cone using a cut parallel to the base. Determine a formula to calculate the volume of a frustum.

$$(V_{cone} = \frac{1}{3} \pi r^2 h)$$

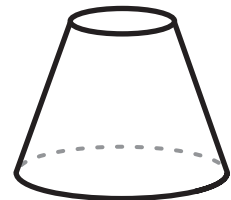

Name: Date: Period:

4

A thirsty crow wants to raise the level of water in a cylindrical container so that it can reach the water with its beak.

- The container has a diameter of 2 inches and a height of 9 inches.
- The crow needs to raise the water level from 6 inches to 8 inches in order to drink from it.

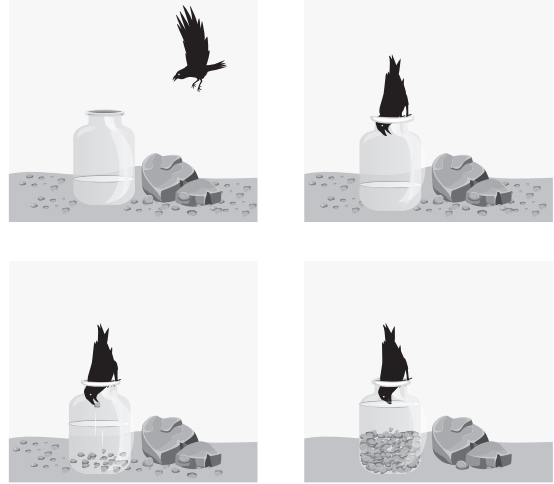

In order to raise the water level, the crow puts spherical pebbles in the container. If the pebbles are approximately $\frac{1}{2}$ inch in diameter, what is the fewest number of pebbles the crow needs to drop into the container in order to reach the water?

5

Here are three identical cubic tanks. The spheres in a given tank are the same size and packed wall-to-wall. If the tanks are filled to the top with water, which tank will hold the most water?

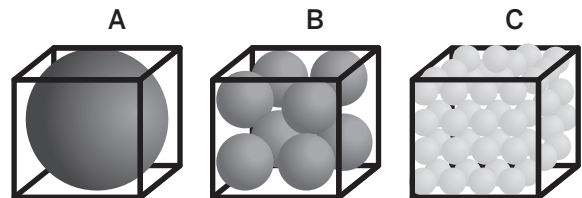

Assign problems to students who want to extend their thinking.

Problems can be solved in any order. If time allows, consider sharing all problems with all students.

Problem 1

Students will extend their understanding of determining the volume of circular solids by investigating the volume of a sphere inscribed in a cylinder.

Provide students with the following hint if additional scaffolding is needed.

- **Hint:** When a sphere is inscribed in a cylinder, it means the sphere touches every face of the cylinder without any gaps. How do you think this helps you to determine the height of the cylinder?

2 : 3

Explanations vary. Because the sphere is inscribed in the cylinder, the height of the cylinder is the same as the diameter of the sphere.

$$V_{\text{cylinder}} = \pi \cdot r^2 h$$

$$V_{\text{cylinder}} = \pi \cdot r^2 \cdot 2r = 2 \cdot \pi \cdot r^3$$

$$V_{\text{sphere}} = \frac{4}{3} \pi \cdot r^3$$

$$\frac{V_{\text{sphere}}}{V_{\text{cylinder}}} = \frac{\frac{4}{3} \pi \cdot r^3}{2 \cdot \pi \cdot r^3} = \frac{\frac{4}{3}}{2} = \frac{2}{3}$$

Problem 2

Students will extend their understanding of determining the volume of circular solids by designing an hourglass made up of a cylinder, a cone and a sphere.

Provide students with the following hint if additional scaffolding is needed.

- **Hint:** How does the volume of each shape relate?

$$h_{\text{cylinder}} = h_{\text{cone}} = 2r$$

Explanations vary. Because the volume of the cylinder must be the sum of the volumes of the cone and the sphere, I wrote:

$$V_{\text{cylinder}} = V_{\text{sphere}} + V_{\text{cone}}$$

$$\pi r^2 h = \frac{4}{3} \pi r^3 + \frac{1}{3} \pi r^2 h, \text{ then I canceled } \pi r^2 \text{ from each term:}$$

$$h_{\text{cylinder}} = \frac{4}{3} r + \frac{1}{3} h_{\text{cone}}$$

If the height of both the cone and the cylinder equals the diameter of the sphere, then the hourglass works perfectly.

Problem 3

Students will extend their understanding of the volume of a cone by applying the volume formula to determine a volume formula for a frustum.

Provide students with the following hint if additional scaffolding is needed.

- **Hint:** Let R be the larger radius of the frustum, r be the smaller radius of the frustum, H be the height of the original cone, and h be the height of the conical piece cut off. Use these variables to help you figure out the formula.

Responses vary. I imagined the original cone before the top piece was cut off. Let R be the larger radius of the frustum, r be the smaller radius of the frustum, H be the height of the original cone, and h be the height of the conical piece which was cut off. Then the formula for the frustum is the volume: $V = \frac{1}{3}(\pi R^2 H - \pi r^2 h)$

Continued next page ...

Problem 4

Students will extend their understanding of determining the volume of circular solids by solving a multi-step problem in a given context.

Provide students with the following hints if additional scaffolding is needed.

- **Hint 1:** The crow just needs to add a volume equal to a cylinder with a height of 2 in. and a radius of 1 in.
- **Hint 2:** What is the volume of each pebble?

96 pebbles. *Explanations vary.*

In order to raise the water level to 8 inches, the crow needs to add a volume of pebbles equivalent to a cylinder with a height of 2 inches and a radius of 1 inch. So the volume is:

$$V = \pi r^2 \cdot h = \pi \cdot 1^2 \cdot 2 = 2\pi$$

Each pebble has a volume of

$$\frac{4}{3} \pi \cdot r^3 = \frac{4}{3} \pi \cdot \left(\frac{1}{4}\right)^3 = \frac{1}{48} \pi$$

Therefore, the crow will need to add

$$2\pi \div \frac{1}{48} \pi = 96 \text{ pebbles.}$$

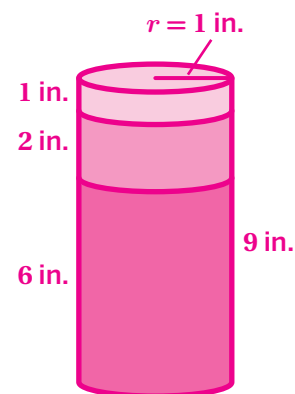

Problem 5

Students will extend their understanding of the volume of a sphere by investigating the ratio of volumes of the spheres and a cube.

Provide students with the following hints if additional scaffolding is needed.

- **Hint 1:** Start with representing the diameter of the large sphere in tank A by $2r$, then determine the side length of the tank.
- **Hint 2:** How many spheres are there in tank B? What are the radii of each of these spheres? What about tank C? How does the relation between the radius of the spheres and the number of spheres affect the total volume of the spheres?

All tanks will hold the same amount of water. *Explanations vary.*

Let the diameter of the sphere in tank A be $2r$. Then the cubic tanks have a volume of $V_{cube} = (2r)^3 = 8r^3$.

- In tank A, sphere A has a volume of $V_A = \frac{4}{3} \pi r^3$.
- In tank B, The total volume of spheres is $V_B = 8 \cdot \frac{4}{3} \pi \left(\frac{r}{2}\right)^3 = \frac{4}{3} \pi r^3$.
- In tank C, The total volume of spheres is $V_C = 64 \cdot \frac{4}{3} \pi \left(\frac{r}{4}\right)^3 = \frac{4}{3} \pi r^3$.

Therefore for each tank, the total volumes of the spheres are the same and the remaining volume for the water is the same.

Unit 8

Extensions

Name: Date: Period:

Student Choice

Start with any problem. Remember to show or explain your thinking.

1

Two standard dice are rolled. What is the probability that the product of the numbers is

- a** odd? **b** even? **c** prime?

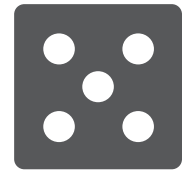
**2**

In a bingo game, each player will have a bingo card of 10 different numbers.

The caller rolls a cubic die (labeled 1–6) and an octahedron die (labeled 1–8), then finds the product to call out.

Players will cover the numbers on their bingo card as they are being called out. The one who covers all of the numbers first, wins.

Pick the numbers on your bingo card to increase your chance of winning the game!

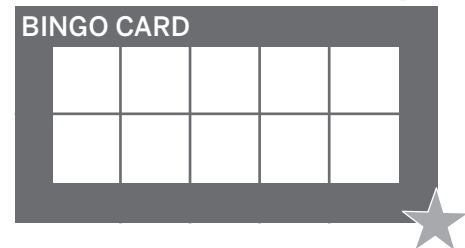
**3**

Here is a dartboard with a circle enclosed by three rings. Noa wants to divide the rings into sections so that every section is equally likely to be hit. (The innermost circle cannot be divided into sections.)

How many divisions should each ring have?

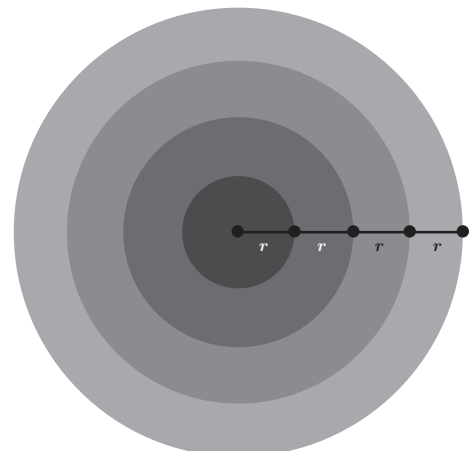

Name: Date: Period:

4

Here is a one layer example of a Galton board. A marble is rolled down from the start. It has a 50% chance of landing in bucket A and 50% chance of landing in bucket B.

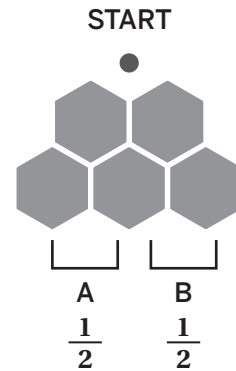

- a Another layer is added to the Galton Board. The probability of the marble ending in bucket C is $\frac{1}{4}$. What is the probability that the marble will land in bucket D? Bucket E?

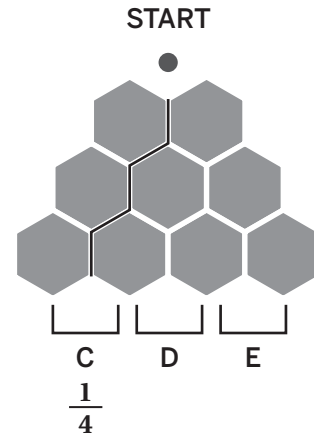

- b One more layer is added to the board. Determine the probabilities for marble to land in each bucket.

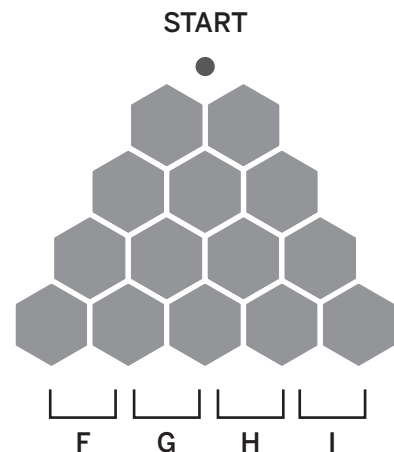

- c How do the outcomes change as a new layer is added to the board? Can you estimate the outcomes in the next layer?

Assign problems to students who want to extend their thinking.

Problems can be solved in any order. If time allows, consider sharing Problems 1–4 with all students.

Materials

- Dice (optional) (Problem 1)

Problem 1

Students will extend their understanding of determining the probability of events by identifying the sample space of rolling two dice.

Provide students with the following hint if additional scaffolding is needed.

- **Hint:** In part c, a prime number is an integer greater than 1 that is only divisible by itself and 1.

a. $\frac{1}{4}$ b. $\frac{3}{4}$ c. $\frac{1}{6}$

Explanations vary.
I determined the sample space to calculate the probabilities.

×						
	1	2	3	4	5	6
	2	4	6	8	10	12
	3	6	9	12	15	18
	4	8	12	16	20	24
	5	10	15	20	25	30
	6	12	18	24	30	36

Problem 2

Students will extend their understanding of determining the probability of events by identifying the sample space of rolling two dice.

Provide students with the following hint if additional scaffolding is needed.

- **Hint:** Determine the sample space to calculate which products have higher probability to be called out.

Responses vary. I would choose 4, 6, 8, 12, 24 initially. Then for the rest of the numbers, I would choose among the set those which have the probability value of $\frac{1}{24}$ instead of $\frac{1}{48}$.

Explanations vary.
I determined the sample space to calculate the probabilities. Then I chose the outcomes with the higher probabilities.

1	1	2	3	4	5	6	7	8
2	2	4	6	8	10	12	14	16
3	3	6	9	12	15	18	21	24
4	4	8	12	16	20	24	28	32
5	5	10	15	20	25	30	35	40
6	6	12	18	24	30	36	42	48

Continued next page ...

Problem 3

Students will extend their understanding of determining the probability of events by creating equally likely sectioned dart areas.

Provide students with the following hint if additional scaffolding is needed.

- **Hint:** Determine the area of the innermost circle. Remember that every section needs to have the same area as the innermost circle.

Divide the first ring by 3, second ring by 5 and the third ring by 7. *Explanations vary.*

The innermost circle has an area of πr^2 .

The first ring that encloses this region has an area of $\pi \cdot (2r)^2 - \pi \cdot r^2 = 3\pi r^2$

The second ring has an area of $\pi \cdot (3r)^2 - \pi \cdot 4r^2 = 5\pi r^2$

And the third ring has an area of $\pi \cdot (4r)^2 - \pi \cdot 9r^2 = 7\pi r^2$

Therefore I would divide the first ring into 3 sections each with an area of πr^2 , then the second ring into 5 sections and the last ring into 7 pieces.

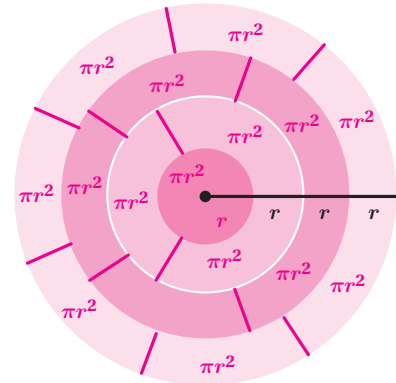

Problem 4

Students will extend their understanding of listing the sample space for a multi-step event by exploring the Galton board and normal distribution.

Provide students with the following hint if additional scaffolding is needed.

- **Hint:** How does the number of sample space increase every time a layer is added to the Galton board?

- $D: \frac{2}{4}$ and $E: \frac{1}{4}$
- $F: \frac{1}{8}, G: \frac{3}{8}, H: \frac{3}{8}$ and $I: \frac{1}{8}$
- Responses vary.* When a new layer is added, the total number of possible outcomes doubles.
 Second layer: $2^2 = 4$ possible outcomes
 Third layer: $2^3 = 8$ possible outcomes
 The fourth layer will have $2^4 = 16$ possible outcomes
 Because the distribution of the outcomes is determined according to the left or right path of the marble, the distribution of possibilities is the same for any two-outcome game, like flipping a coin.

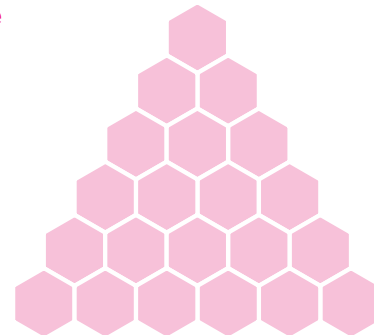
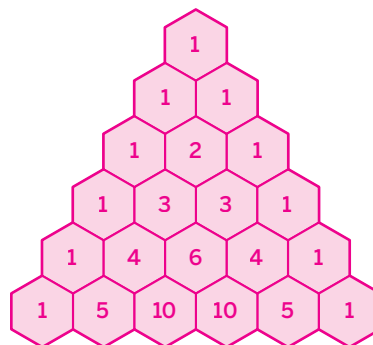

- LLLL
- RLLL
- LRLR
- LRRL
- LLRL
- LLLR
- RLLR
- RRLL
- RRLR
- RRRL
- RLRL
- RLRR
- RLLR
- LLRR

Name: Date: Period:

Student Choice

Start with any problem. Remember to show or explain your thinking.

1

Political parties often use samples to poll people about important issues. One common method is to call people and ask their opinions. In most places, though, they are not allowed to call cell phones. Explain how this restriction might lead to inaccurate samples of the population.

2

Here is 6 by 6 grid showing the ages of kids in a youth camp.

- a** Roll two dice showing the row and column number to pick 8 random numbers to calculate their mean.
- b** Compare each of these measures of center and spread for the population and the sample. What do you notice?
- Mean:
 - Median:
 - Mode:
 - Range:
 - IQR:

12	10	15	9	16	21
10	17	12	13	16	16
14	15	10	12	18	19
17	20	15	8	15	12
12	12	16	21	15	14
10	12	12	16	13	10

Name: Date: Period:

3

How can you make an educational guess to determine the number of marbles in a 20 by 20 frame.

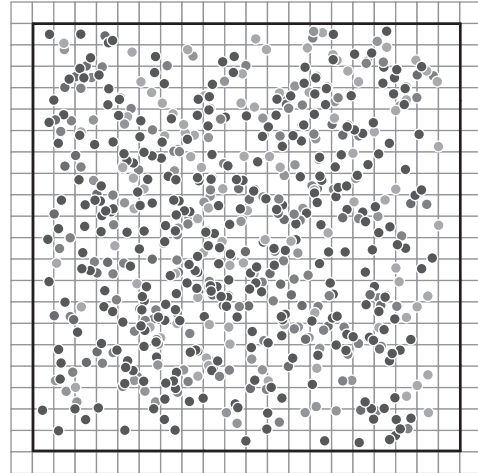

4

Here are the readings of a speed sensor in front of a school.

Sample data on the speeds of vehicles traveling

East (mph)	West (mph)
26, 30, 39, 34, 40, 21	25, 35, 27, 34, 40, 22
25, 20, 24, 26, 22, 32	20, 19, 18, 20, 19, 30

- a** Make a double box-and-whiskers diagram to represent the east and west end speeds (mph).
- b** Which measure would you use to convince the city council to add a stop sign to the east end? West end? Both?

Assign problems to students who want to extend their thinking.

Problems 1–4 can be solved in any order. If time allows, consider sharing Problems 1–4 with all students.

Problem 1

Students will extend their understanding of the terms population and sample by critiquing a real-world scenario.

Provide students with the following hint if additional scaffolding is needed.

- **Hint:** Can all the people be reachable by their home phones?

Responses vary.

- Some people, especially younger people, may only have cell phones, so they will not be included in the sample. This may lead to more information being gathered from older people than younger people, and the information may not accurately represent everyone.
- If the polls are only calling home phones, they are only reaching individuals who work from home, do not work, or do not work during the day. This may lead to more information being gathered from this specific type of person, and may not accurately represent everyone.

Problem 2

Students will extend their understanding of sampling by comparing the center and spread measures of a random sample with the population.

Provide students with the following hints if additional scaffolding is needed.

- **Hint 1:** If the central measures of the entire grid and your sample are close, what does this tell you about the tendency of your sample?
- **Hint 2:** If the variability measures are close what does this tell you about the spread of your sample?

a. Sample

Responses vary.

I rolled for the sample 12, 10, 15, 10, 17, 21, 19, 12.

Mean: 14.5
Median: 13.5
Mode: 10, 12
Range: 11
IQR: 7

b. Entire Grid

Mean: ≈ 14.03
Median: 14
Mode: 12
Range: 13
IQR: 4

The mean of the sample, 14.5, is quite close to the mean of the full data set ≈ 14.03 , suggesting that this sample is a reasonable representation of the average of the larger set. The range of the sample, 11, is slightly smaller than the range of the full set, 13. This indicates that the sample doesn't fully capture the extreme values of the larger set but still represents a similar spread.

However, there are some minor differences in the median, mode, and IQR. The median and mode indicate a slight shift towards lower values in the sample, and the higher IQR suggests that there is a bit more variability in the sample compared to the middle values of the full set.

Continued next page ...

Problem 3

Students will extend their understanding of the purpose of sampling by exploring the methods of obtaining a representative sample.

Provide students with the following hint if additional scaffolding is needed.

- **Hint:** If you can insert a smaller square and count the number of marbles in it, how would you proceed to determine the total number of marbles? Where would you choose to insert the square?

Responses vary. Approximately 750 marbles.

Explanations vary. I drew a 4 by 4 square in the 20 by 20 grid and counted the number of marbles. I chose the square in a region that I thought best represents the entire grid. There were 30 marbles.

Then I determined the ratio of my square to the entire grid; $\frac{4 \times 4}{20 \times 20} = \frac{1}{25}$, then I determined the total number of marbles by $30 \cdot 25 = 750$.

Problem 4

Students will extend their understanding of using measures of center and variability from random samples to draw conclusions by convincing the city council to add stop signs in front of a school.

Provide students with the following hint if additional scaffolding is needed.

- **Hint:** Determine the mean, mode, median, range, and IQR of both samples to compare.



b. *Responses vary.*

- **East End:** I would use the mean speed of 28.25 miles per hour, which is higher than on the west side, and the presence of vehicles traveling at speeds up to 40 miles per hour.
- **West End:** I would use the range and IQR. Despite the lower mean and median, some vehicles are traveling at 40 miles per hour, and the IQR of 14 suggests more variability, with some drivers potentially posing a safety risk.
- **Both Ends:** I would use the extremes of 40 miles per hour in both directions, especially near a school zone. I argue for stop signs at both ends to ensure safer, slower traffic flow in both directions.

Amplify. For more information visit amplify.com

ISBN 9798895804803



9 798895 804803